



Improved System for Large-Scale Production of Metal Matrix Nanocomposites

[View U.S. Patent No. 8,865,057 in PDF format.](#)

WARF: P110292US01

Inventors: Xiaochun Li, Noe Alba-Baena, Daniel Hoefert, David Weiss, Woo-hyun Cho, Ben Slater, Hongseok Choi

The Wisconsin Alumni Research Foundation (WARF) is seeking commercial partners interested in developing an apparatus and a method for the industrial-scale production of metal matrix nanocomposites.

Overview

A nanocomposite is a reinforcing material that can be added to conventional materials to make them lightweight and ductile while also increasing their strength. Nanocomposites having high strength-to-weight ratios are of interest to a number of industries because they can be produced at low cost with properties comparable to more conventional, heavier materials.

Metal matrix nanocomposites (MMNCs) are a type of nanocomposite in which nanoparticles are added to a metal matrix. MMNCs are advantageous because they can be made from relatively inexpensive, abundant metals with strengths comparable to those of more expensive alloys. Current methods of producing MMNCs rely on a system involving an ultrasonic probe, which is impractical to scale-up to a size suitable for industrial-scale production; thus, their use has been limited. A new method for the large-scale production of MMNCs is needed.

The Invention

UW–Madison researchers have developed an apparatus for producing metal matrix nanocomposites on an industrial scale. The apparatus has three main integrated systems: a nanoparticle feeding system, a mechanical mixing system and a cavitation system. The apparatus also comprises a production chamber defining a cavity and a pumping conduit. In addition, the researchers have developed a method for producing MMNCs that involves introducing nanoparticle agglomerates into a volume of molten metal, wherein a flow is created that continuously carries the nanoparticle agglomerates.

Applications

- Making cast metal nanocomposites at industrial foundries

Key Benefits

- Industrial-scale production of MMNCs
- No need for concurrent scale-up of the cavitation device or cavitation zone
- Can be scaled to various sizes

Stage of Development

We use cookies on this site to enhance your experience and improve our marketing efforts. By continuing to browse without changing your browser settings to block or delete cookies, you agree to the storing of cookies and related technologies on your device. [See our privacy policy.](#)

Additional Information

OK

Related Intellectual Property

- [View Divisional Patent in PDF format.](#)

Tech Fields

- [Materials & Chemicals : Composites](#)

For current licensing status, please contact Michael Carey at mcarey@warf.org or 608-960-9867

Figures

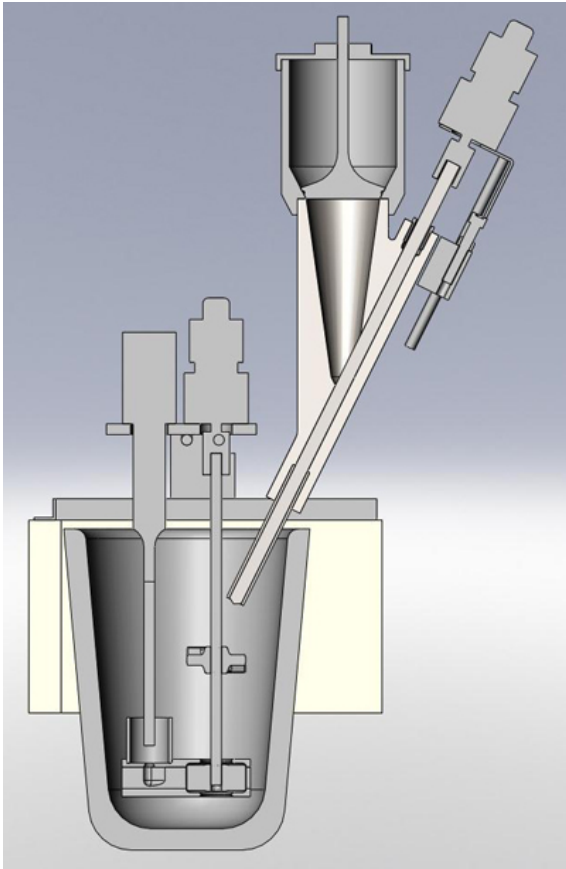

We use cookies on this site to enhance your experience and improve our marketing efforts. By continuing to browse without changing your browser settings to block or delete cookies, you agree to the storing of cookies and related technologies on your device. [See our privacy policy.](#)

OK

