



US010807094B2

(12) **United States Patent**
Beebe et al.

(10) **Patent No.:** **US 10,807,094 B2**
(45) **Date of Patent:** **Oct. 20, 2020**

(54) **DEVICE AND METHOD TO FACILITATE THE PREPACKAGING, HANDLING AND USE OF SMALL VOLUMES OF FLUIDS**

(56) **References Cited**

U.S. PATENT DOCUMENTS

(71) Applicant: **Wisconsin Alumni Research Foundation**, Madison, WI (US)

2012/0277697 A1* 11/2012 Haghgoie A61B 5/1411 604/319

(72) Inventors: **David J. Beebe**, Monona, WI (US);
Jay W. Warrick, Madison, WI (US);
David J. Guckenberger, Jr., Oconomowoc, WI (US)

2014/0309096 A1* 10/2014 Wilkinson A61B 5/150305 494/43

(73) Assignee: **Wisconsin Alumni Research Foundation**, Madison, WI (US)

OTHER PUBLICATIONS

“Rapid DNA Isolation From Mammalian Cell Lysates using the Gilson Extractman(TM)”, Gilson, Inc., Middleton, WI 53562, downloaded from www.gilson.com/Resources/TRANS0615_EXTRACTMAN_DNA.pdf on Dec. 30, 2016.

(*) Notice: Subject to any disclaimer, the term of this patent is extended or adjusted under 35 U.S.C. 154(b) by 991 days.

* cited by examiner

(21) Appl. No.: **15/277,029**

Primary Examiner — Walter D. Griffin

Assistant Examiner — Shuyi S. Liu

(22) Filed: **Sep. 27, 2016**

(74) *Attorney, Agent, or Firm* — Boyle Fredrickson, S.C.

(65) **Prior Publication Data**

US 2018/0085748 A1 Mar. 29, 2018

(51) **Int. Cl.**
B01L 3/00 (2006.01)

(52) **U.S. Cl.**
CPC **B01L 3/52** (2013.01); **B01L 3/561** (2013.01); **B01L 3/563** (2013.01); **B01L 2300/043** (2013.01); **B01L 2300/0832** (2013.01); **B01L 2400/0409** (2013.01)

(58) **Field of Classification Search**
CPC B01L 3/52; B01L 2400/0409; B01L 3/563; B01L 3/561; B01L 2300/0832; B01L 2300/043
USPC 494/16, 20
See application file for complete search history.

(57) **ABSTRACT**

A device and method are provided to facilitate the handling of a volume or fluid. The device includes an elongated tube having an open first end and a second end. The tube defines a reservoir for receiving the volume or fluid. A stanchion has a first end received within the reservoir of the tube and a second end projecting from the open end of the elongated tube. In operation, the elongated tube is deposited in a first capsule having fluid therein. The first capsule is centrifuged such that the volume of fluid is received in a reservoir in the tube through the open end. The tube is removed from the first capsule and positioned in a second capsule such that the open end of the tube is spaced from a closed end of the second capsule. The second capsule is centrifuged such that the volume of fluid is expelled from the reservoir of the tube.

8 Claims, 4 Drawing Sheets

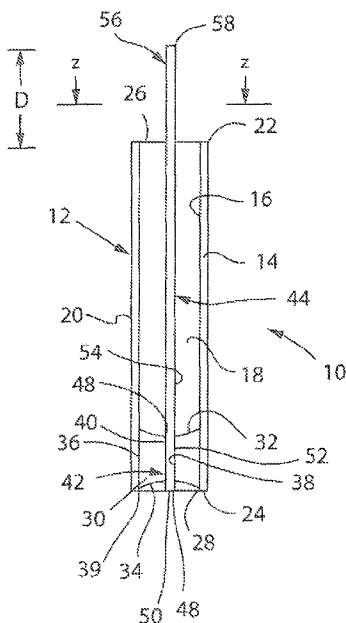

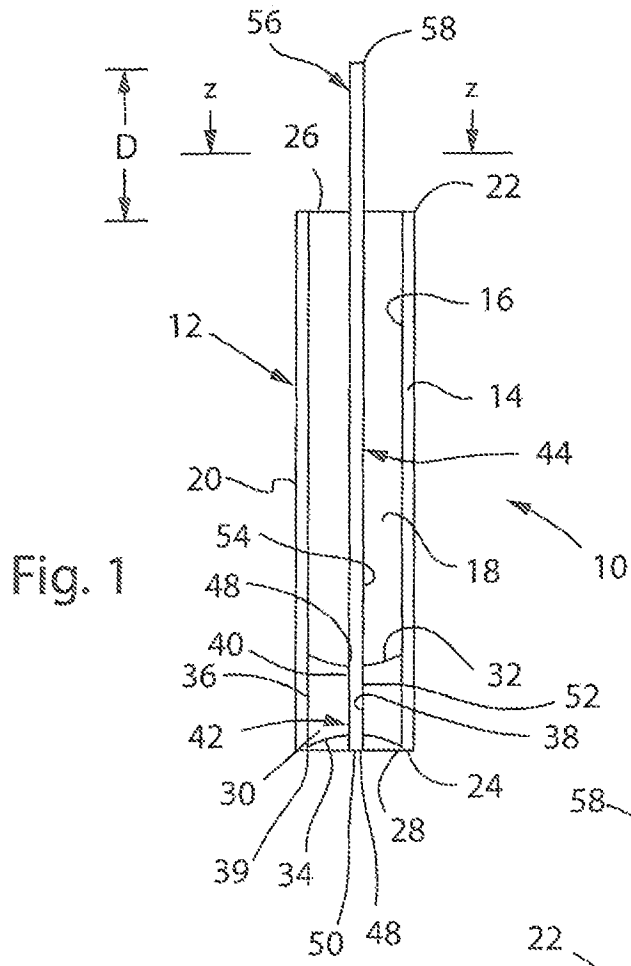

Fig. 1

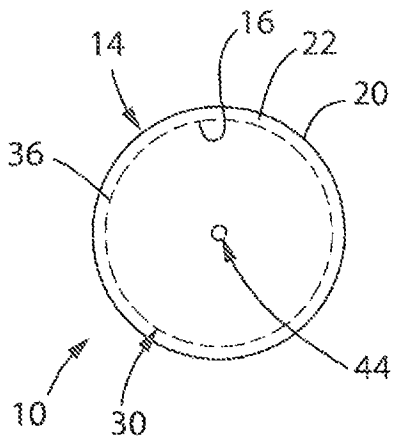

Fig. 2

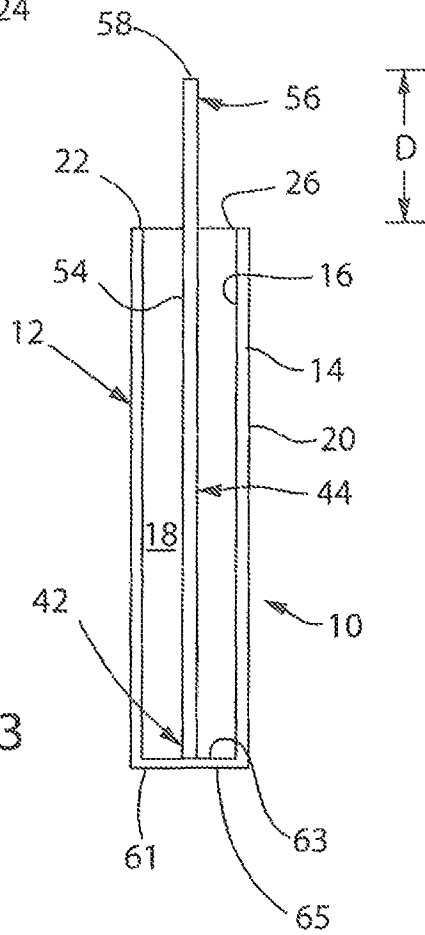

Fig. 3

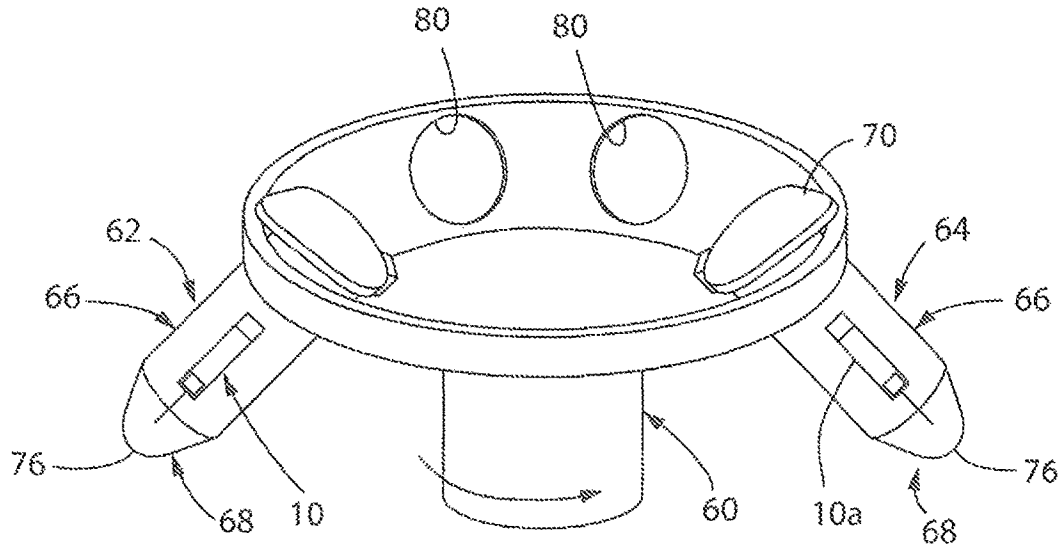

Fig. 4

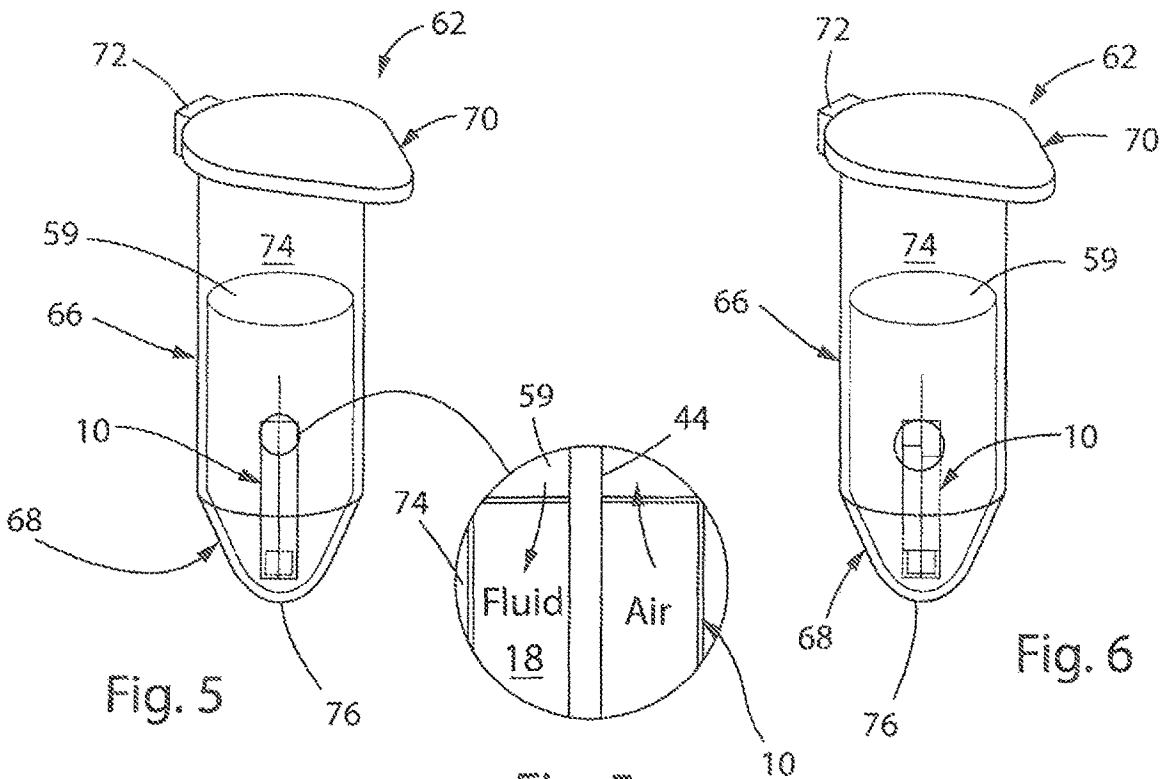
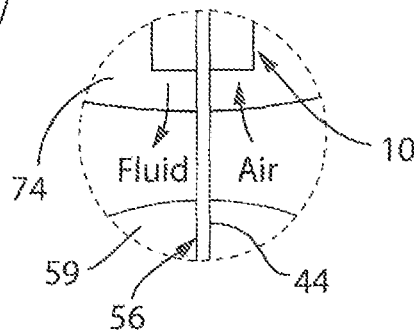
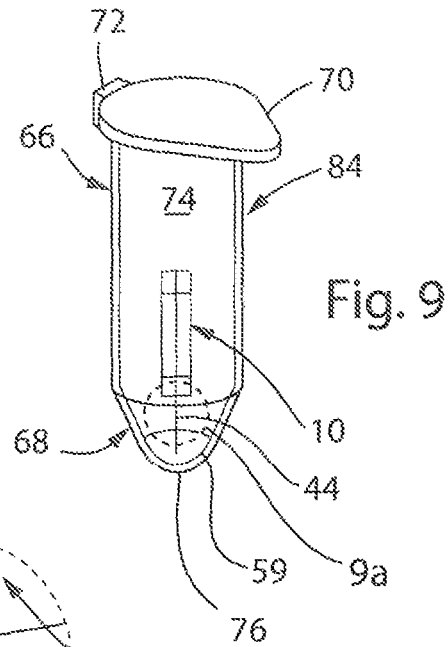
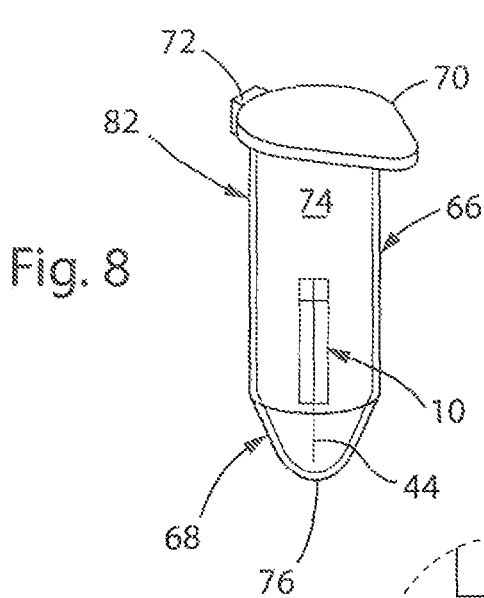
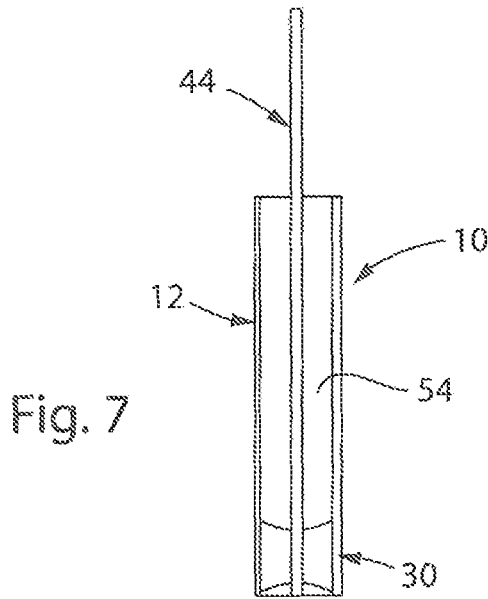

Fig. 5

Fig. 5a

Fig. 6



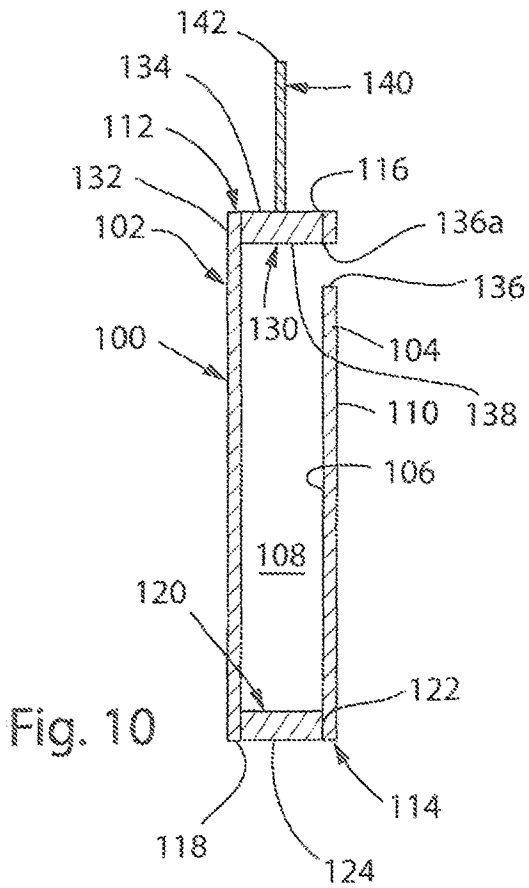

Fig. 10

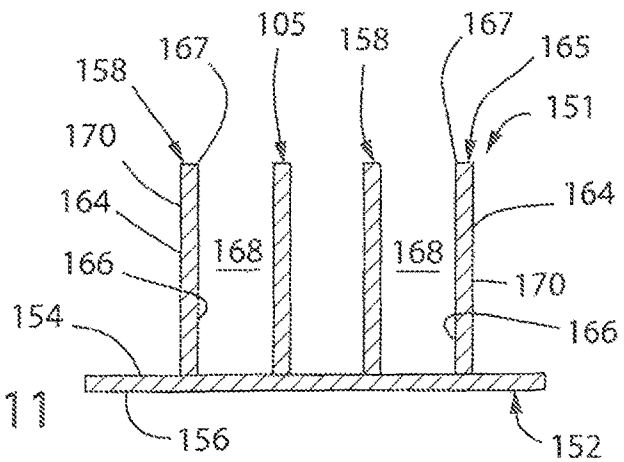

Fig. 11

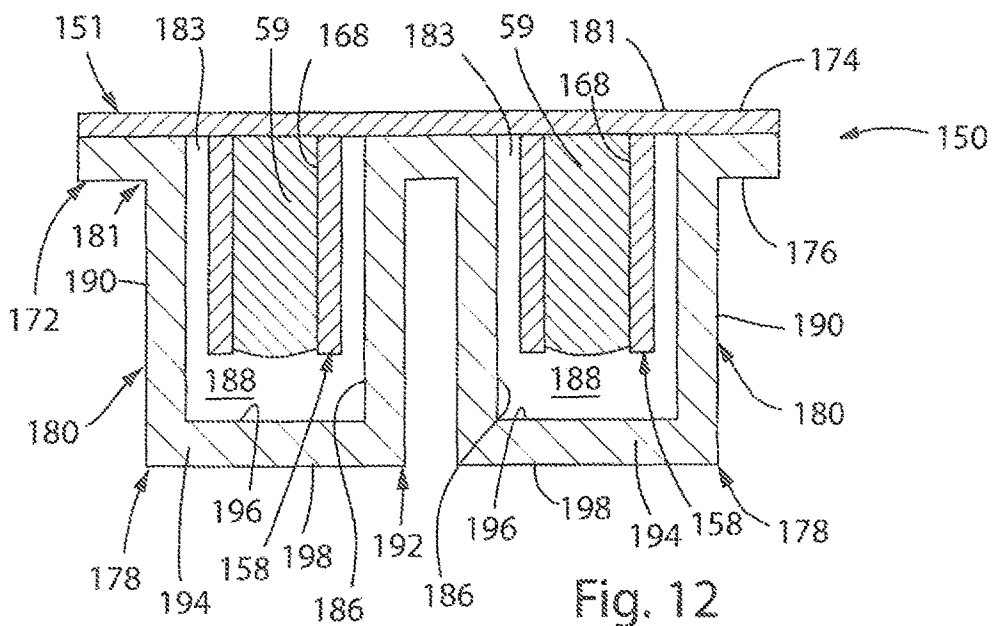

Fig. 12

**DEVICE AND METHOD TO FACILITATE
THE PREPACKAGING, HANDLING AND
USE OF SMALL VOLUMES OF FLUIDS**

REFERENCE TO GOVERNMENT GRANT

This invention was made with government support under CA160344 awarded by the National Institutes of Health. The government has certain rights in the invention.

FIELD OF THE INVENTION

This invention relates generally to microfluidic devices, and in particular, to a device and method to facilitate the prepackaging, handling and use of small volumes of fluids.

BACKGROUND AND SUMMARY OF THE
INVENTION

Due to the lower cost, simpler protocols, and less reagent waste, assays are continually transforming towards the smaller scale. Unfortunately, this transformation and the general acceptance of microscale technologies has been slowed due to both technological limitations and the lack of general acceptance by users. More specifically, users are skeptical of new technologies that differ significantly from those to which they are accustomed. Hence, in order to gain acceptance by users, microscale technologies must be reliable and easy to use. Further, the technology must be transitional, so as to constitute an incremental step from current technologies.

To facilitate and to simplify assays and facilitate distribution of microscale technologies, kits have been developed which include all of the reagents and protocols necessary to complete a task. Despite this transition, methods of prepackaging small volumes (e.g., nano- to micro-liter volumes) of reagents remain limited. In addition, even if small volumes of the reagent were prepackaged in a standard tube, recovery of these small volumes of the reagent can be difficult, if not impossible, thereby requiring excess volume of the reagent to be shipped to the user. Thus, it can be appreciated that a technology which enables the prepackaging of small volumes of reagents and enables full recovery of the reagent could bring forth a paradigm shift in the use of microscale technologies.

It is noted that small volume fluid handling capabilities are ubiquitous and required by both industry and academics, spanning multiple disciplines, including: biology, pharmacology, and agriculture, to list a few. The standard tool, used by almost every lab, for measuring and manipulating small volumes of fluids is the pipette. Pipettes have a usable range from approximately 0.2 microliters (μl) to 25 milliliters (ml), with the most accurate low-volume pipettes having a usable range from 0.2 μl to 2 μl . Despite its usable range, these low-volume pipettes carry high levels of imprecision, which increases as the volume decreases. The most prominent sources for this imprecision come from: 1) fluid stuck to the walls (both inside and outside walls) of the pipette; and 2) improper pipetting techniques, both of which are amplified when pipetting high viscosity or low surface energy fluids. This imprecision represents difficulties for many assays which require measurement of small volumes, including: PCR, staining assays, etc. Thus, a technology that can more precisely measure small volumes of fluid, despite the viscosity or surface energy of the fluid, would enable new assays and provide value.

Therefore, it is a primary object and feature of the present invention to provide a device and method to facilitate the prepackaging, handling and use of small volumes of fluids.

It is a further object and feature of the present invention to provide a device and method to facilitate the prepackaging, handling and use of small volumes of fluids that are amenable to a wide variety of reagents.

It is a still further object and feature of the present invention to provide a device to facilitate the prepackaging, handling and use of small volumes of fluids that is simple to manufacture and easy to use.

In accordance with the present invention, a device is provided to facilitate the handling of a volume of fluid. The device includes an elongated tube having an open first end and a second end. The tube defines a reservoir for receiving the volume of fluid. A stanchion has a first end received within the reservoir of the tube and a second end projecting from the open end of the elongated tube.

The reservoir has a volume less than 10 microliters, and preferably in the range of 0.01 microliters to 6 microliters. The tube has a diameter in the range of 50 micrometers to 1.5 millimeters and a length of 1 millimeter and 15 millimeters. The second end of the tube may be closed, for example, by a seal provided in the second end of the tube. The first end of the stanchion may be fixed to the seal.

In accordance with a further aspect of the present invention, a method is provided for facilitating the handling of volume of fluid. The method includes the step of positioning an elongated tube in a first capsule having the fluid therein. The tube has an open end. The first capsule is centrifuged such that the volume of fluid is received in the tube through the open end.

After the first capsule is centrifuged, the tube is removed from the first capsule. Thereafter, the tube may be positioned in a second capsule free of fluid and having a closed end such that the open end of the tube is spaced from the closed end of the second capsule. The second capsule is centrifuged such that the volume of fluid is expelled from the tube into the second capsule.

It is contemplated for the open end of the tube to be spaced from the closed end of the second capsule by a stanchion. The stanchion extends from the open end of the tube. The tube also includes a second end which is closed, for example, by a seal received within the second end of the tube. The stanchion has a first end fixed within the tube, e.g., to the seal, and a second end positioned outside of the tube.

In accordance with a further, aspect of the present invention, a method is provided for facilitating the handling a volume of fluid. The method includes the step of positioning an elongated tube having a reservoir and an open end communicating with the reservoir in a first capsule such that the open end of the tube is spaced from a closed end of the first capsule. The reservoir includes the volume of fluid therein. Thereafter, the first capsule is centrifuged such that the volume of fluid is expelled from the reservoir of the tube into the first capsule.

Prior to positioning the tube in the first capsule, the method may include the additional steps of positioning the tube in a second capsule having the fluid therein; and centrifuging the second capsule such that the volume of the fluid is urged into the tube through the open end. The open end of the tube is spaced from the closed end of the first capsule by a stanchion. The stanchion extends from the open end of the tube. The tube also includes a second end that is closed by, for example, a seal. The stanchion has a first end fixed within the tube, e.g., to the seal, and a second end positioned outside of the tube.

In accordance with a still further aspect of the present invention, a method is provided for facilitating the handling of a volume of fluid. The method includes the step of positioning an elongated tube in a first capsule having fluid therein. The tube has an open end. The first capsule is centrifuged such that the volume of fluid is received in a reservoir in the tube through the open end. The tube is removed from the first capsule and positioned in a second capsule such that the open end of the tube is spaced from a closed end of the second capsule. The second capsule is centrifuged such that the volume of fluid is expelled from the reservoir of the tube.

The tube includes a second end that is closed, e.g., by a seal. The open end of the tube is spaced from the closed end of the second capsule by a stanchion. The stanchion has a first end fixed within the tube, e.g., to the seal, and a second end positioned outside of the tube.

BRIEF DESCRIPTION OF THE DRAWINGS

The drawings furnished herewith illustrate a preferred construction of the present invention in which the above aspects, advantages and features are clearly disclosed as well as others which will be readily understood from the following description of the illustrated embodiments.

In the drawings:

FIG. 1 a schematic, cross-sectional view of a device to facilitate the prepackaging, handling and use of small volumes of fluids in accordance with the present invention;

FIG. 2 is a cross-sectional view of the device of the present invention taken along line 2-2 of FIG. 1;

FIG. 3 is a schematic, cross-sectional view of an alternate configuration of a device to facilitate the prepackaging, handling and use of small volumes of fluids in accordance with the present invention;

FIG. 4 is a schematic, isometric view of a first and second devices in accordance with the present invention received within into corresponding capsules of a conventional centrifuge;

FIG. 5 is an enlarged, isometric view of a first capsule having the device in accordance with the present invention received therein prior to being centrifuged with the centrifuge of FIG. 4 and prior to being filled with a volume of a fluid;

FIG. 5a is an enlarged, schematic view showing a portion of the first capsule of is FIG. 5;

FIG. 6 is an enlarged, isometric view of the first capsule having the device in accordance with the present invention received therein after being centrifuged with the centrifuge of FIG. 4 and after being filled with the volume of fluid;

FIG. 7 is a schematic, cross-sectional view of the device in accordance with the present invention after being filled with the volume of fluid;

FIG. 8 is an enlarged, isometric view of a second capsule having the device of FIG. 7 received therein prior to being centrifuged with the centrifuge of FIG. 4 and prior to the volume of a fluid being expelled from the device;

FIG. 9 is an enlarged, isometric view of the second capsule having the device received therein after being centrifuged with the centrifuge of FIG. 4 and after the volume of fluid has been expelled from the device and into the second capsule;

FIG. 9a is an enlarged, schematic view showing a portion of the second capsule of FIG. 5;

FIG. 10 is a schematic, cross-sectional view of an alternate embodiment of a device to facilitate the prepackaging, handling and use of small volumes of fluids in accordance with the present invention;

FIG. 11 is a schematic, cross-sectional-view of a still further embodiment of a device to facilitate the prepackaging, handling and use of small volumes of fluids in accordance with the present invention received within into a corresponding capsule of a conventional centrifuge prior to being filled with a volume of a fluid; and

FIG. 12 is a schematic, cross-sectional view of the device of FIG. 11 received within into a corresponding capsule of a conventional centrifuge prior to the volume of a fluid being expelled from the device.

DETAILED DESCRIPTION OF THE DRAWINGS

Referring to FIGS. 1-2, a device to facilitate the prepackaging, handling and use of small volumes of fluids in accordance with the present invention is generally designated by the reference numeral 10. Device 10 includes a generally cylindrical tube 12 defined by wall 14. Wall 14 includes a generally cylindrical inner surface 16 defining a reservoir 18 for receiving a volume of fluid therein, as hereinafter described, and a generally cylindrical outer surface 20. While tube 12 is depicted as being cylindrical in the drawing figures, it can be appreciated the other configurations are possible without deviating from the scope of the present invention. By way of example, it is contemplated for tube 12 to have a generally square or rectangular cross-section.

Wall 14 includes a first upper end 22 and a second lower end 24. Upper and lower ends 22 and 24, respectively, define corresponding upper and lower orifices 26 and 28, respectively, which communicate with reservoir 18. Seal 30 is receivable in reservoir 18 of tube 12 through lower orifice 28. Seal 30 extends along a longitudinal axis and includes a generally concave upper surface 32 and a generally concave lower surface 34 interconnected by a generally cylindrical outer surface 36 and a generally cylindrical inner surface 38 radially spaced therefrom. With seal 30 received within reservoir 18 of tube 12, it is intended for outer surface 36 of seal 30 to form a fluidic seal with inner surface 16 of wall 14 so as to prevent fluid received in reservoir 18 from exiting reservoir 18 through orifice 28. In the depicted embodiment, radially outer edge 39 at the intersection of lower surface 34 and outer surface 36 of seal 30 is generally coplanar with lower end 24 of wall 14.

Inner surface 38 of seal 30 includes an upper edge intersecting upper surface 32 of seal 30 so as to define opening 46 and a lower edge intersecting lower surface 34 of seal 30 so as to define opening 48. Inner surface 38 of seal 30 defines a passageway 40 which extends between openings 46 and 48 along the longitudinal axis of seal 30 and which is adapted for receiving a lower end 42 of stanchion 44, as hereinafter described. Openings 46 and 48 are centrally located in upper and lower surfaces 32 and 34, respectively, of seal 30, for reasons hereinafter described.

As previously noted, lower end 42 of stanchion 44 is received within passageway 40 of seal 30 such that lower surface 50 of stanchion 44 is substantially coplanar with lower end 24 of wall 14. It is intended for portion 52 of outer surface 54 of stanchion 44 to engage inner surface 38 of seal 30 so as to form a fluidic seal therewith and prevent fluid received in reservoir 18 from exiting reservoir 18 through passageway 40 in seal 30. With lower end 42 received within passageway 40 of seal 30, stanchion 44 extends axially

along the longitudinal axis of seal **30** and through reservoir **18** such that upper end **56** of stanchion **44** is positioned outside of tube **12**. More specifically, upper surface **58** of stanchion **44** lies in a plane generally parallel to and spaced from a plane containing upper end **22** of wall **14** by a distance **D**.

Referring to FIG. 3, it is contemplated to substitute seal **30** in device **10** with bottom wall **61** which closes lower end **24** of wall **14**. More specifically, bottom wall **61** includes a generally flat, upper surface **63** directed towards reservoir **18** and a generally flat, lower surface **65**. It is intended for bottom wall **61** to prevent fluid received in reservoir **18** from exiting reservoir **18** therepast. Lower end **42** of stanchion **44** is fixed to the center of upper surface **63** of bottom wall **61** in any suitable manner. Stanchion **44** extends axially along the longitudinally axis of tube **12** and through reservoir **18** such that upper end **56** of stanchion **44** is positioned outside of tube **12**. More specifically, upper surface **58** of stanchion **44** lies in a plane generally parallel to and spaced from a plane containing upper end **22** of wall **14** by a distance **D**.

In operation, in order to fill reservoir **18** of tube **12** with a desired volume of a fluid, such as reagent **59**, reagent **59** is provided in capsules of a conventional centrifuge machine **60**. Referring to FIG. 4, by way of example, first and second capsules **62** and **64**, respectfully, are provided. First and second capsules **62** and **64**, respectfully, are identical in structure. As such, the description of first capsule **62** is understood to describe second capsule **64** as if fully described herein. First capsule **62** includes cylindrical body portion **66** having a generally conical or tapered portion **68** depending from the lower end **70** thereof. Tapered portion **68** of first capsule **62** terminates at closed tip **76**. It is contemplated for a radially extending flange (not shown) to project from an upper end of cylindrical body portion **66**. The flange projecting from the upper end of cylindrical body portion **66** is adapted to mate with lid **70**. Lid **70** is attached to cylindrical body portion **66** by lid hinge **72** and is pivotable on lid hinge **72** between an open position allowing access to interior **74** of first capsule **62** and a closed position wherein interior **74** of first capsule **62** is isolated from the external environment.

With lid **70** of first capsule **62** in an open position, device **10** is positioned within interior **74** of first capsule **62** such that lower surface **34** of seal **30** is directed towards closed tip **76** of tapered portion **68** of first capsule **62**. In addition, interior **74** of first capsule **62** is filled with a sufficient volume of a desired reagent **59** such that desired reagent **59** overlaps upper orifice **26** defined by wall **14** of tube **12**. Thereafter, lid **70** is moved to the closed position and first capsule **62** is deposited in a corresponding retainer **80** in centrifuge machine **60**. In a similar manner, a second device **10a**, identical to device **10**, is positioned within interior **74** of second capsule **64** such that lower surface **34** of seal **30** is directed towards closed tip **76** of tapered portion **68** of second capsule **64**. In addition, interior **74** of second capsule **64** is filled with a sufficient volume of a desired reagent **59** such that desired reagent **59** in second capsule **64** overlaps upper orifice **26** defined by wall **14** of tube **12** of second device **10a**. Thereafter, lid **70** is moved to the closed position and second capsule **64** is deposited in a corresponding retainer **80** in centrifuge machine **60**.

With first and second capsules **62** and **64**, respectively, received in corresponding retainers **80** in centrifuge machine **60**, centrifuge machine **60** is actuated so as to centrifuge first and second capsules **62** and **64**, respectively, for a desired time period (e.g. 30 seconds) at user selected revolutions per minute. As first and second capsules **62** and **64**, respectively,

(and hence, first and second devices **10** and **10a**, respectively) are centrifuged, portions of reagents **59** in first and second capsules **62** and **64**, respectively, are urged into corresponding reservoirs **18** in devices **10** and **10a** such that the air, previously in reservoirs **18**, is expelled therefrom, FIG. 5a. The volume of fluid received in reservoirs **18** of devices **10** and **10a** is controlled by the geometry and the volume of reservoirs **18**. In the depicted embodiment, reservoirs **18** of devices **10** and **10a** have a generally cylindrical configuration. However, other configurations are possible without deviating from the scope of the present invention. By way of example, it is contemplated for each reservoir **18** to have a volume less than 10 microliters, and preferably, in the range of 0.01 microliters to 6 microliters. Reservoir **18** may have a diameter in the range of 50 micrometers to 1.5 millimeters and a length in the range of 1 millimeter and 15 millimeters. More specifically, it is contemplated for reservoir **18** to have a diameter of approximately 0.66 mm and a length of approximately 8 mm. However, other diameters and lengths are possible without deviating from the scope of the present invention.

Referring to FIG. 7, once reservoirs **18** are filled with reagents **59**, as heretofore described, devices **10** and **10a** may be removed from corresponding capsules **62** and **64**, respectively. These "prepackaged" devices **10** and **10a** may be transported to an end user. It is noted that small areas of upper orifices **26** in devices **10** and **10a** severely limit evaporation, and hence, mitigate the risk of evaporative loss of reagent **59** from reservoirs **18**. Further, it is noted that seal **30** receivable in lower orifice **28** of each tube **12** and the small nature of upper orifice **26** prevent loss of reagent **59** from each reservoir **18** in response to an inertial catastrophe, such as the dropping of device **10** and **10a**.

Referring to FIGS. 8-9a, in order to remove the reagents from reservoirs **18** of devices **10** and **10a**, devices **10** and **10a** are positioned with corresponding third and fourth capsules **82** and **84**, respectively. Third and fourth capsules **82** and **84**, respectfully, are identical in structure to first capsule **62**. As such, the description of first capsule **62** is understood to describe third and fourth capsules **82** and **84**, respectively, as if fully described herein.

Device **10** is positioned within interior **74** of third capsule **82** such that upper end **56** of stanchion **44** is directed towards, and preferably engages, closed tip **76** of tapered portion **68** of third capsule **82**. Thereafter, lid **70** is moved to the closed position and third capsule **82** is deposited in a corresponding retainer **80** in centrifuge machine **60**. In a similar manner, a second device **10a**, identical to device **10**, is positioned within interior **74** of second capsule **84** such that upper end **56** of stanchion **44** is directed towards, and preferably engages, closed tip **76** of tapered portion **68** of fourth capsule **84**. Thereafter, lid **70** is moved to the closed position and fourth capsule **84** is deposited in a corresponding retainer **80** in centrifuge machine **60**.

With third and fourth capsules **82** and **84**, respectively, received in corresponding retainers **80** in centrifuge machine **60**, centrifuge machine **60** is actuated so as to centrifuge third and fourth capsules **82** and **84**, respectively, for a desired time period (e.g. 30 seconds) at user selected revolutions per minute. As third and fourth capsules **82** and **84**, respectively, (and hence, first and second devices **10** and **10a**, respectively) are centrifuged, reagents **59** in reservoirs **18** of devices **10** and **10a** are urged from reservoirs **18** and into corresponding interiors **74** of third and fourth capsules **82** and **84**, respectively, FIG. 9a. It can be appreciated that during the centrifugation process, stanchion **44** maintains upper orifices **26** of devices **10** and **10a** in spaced relation to

closed tips 76 of tapered portions 68 of third and fourth capsules 82 and 84, respectively, thereby assuring that all of the fluidic contents of reservoirs 18 has been expelled from devices 10 and 10a into corresponding interiors 74 of third and fourth capsules 82 and 84, respectively. At this point, the nano- or micro-volumes of reagents 59 have been delivered to interiors 74 of third and fourth capsules 82 and 84, respectively, and are accessible for downstream dilutions or applications.

It is noted that since devices 10 and 10a are small, a number of devices 10 and 10a can be bundled together in a single capsule, e.g., first capsule 62, so as to allow for the simultaneous filling of multiple devices 10 and 10a. Further, it is understood that a number of devices 10 and 10a containing different reagents can be bundled together in a single capsule, e.g., third capsule 82, so as to allow for the simultaneous delivery of several different reagents to the interior 74 of such capsule.

Referring to FIG. 10, an alternate embodiment of a device to facilitate the prepackaging, handling and use of small volumes of fluids in accordance with the present invention is generally designated by the reference numeral 100. Device 100 includes a generally cylindrical tube 102 defined by wall 104. Wall 104 includes a generally cylindrical inner surface 106 defining a reservoir 108 for receiving a volume of fluid therein, as hereinafter described, and a generally cylindrical outer surface 110. While tube 102 is depicted as being cylindrical in the drawing figures, it can be appreciated the other configurations are possible without deviating from the scope of the present invention. By way of example, it is contemplated for tube 102 to have a generally square or rectangular cross-section.

Wall 104 includes a first upper end 112 and a second lower end 114. Upper and lower ends 112 and 114, respectively, define corresponding upper and lower orifices 116 and 118, respectively, which communicate with reservoir 108. Seal 120 is receivable in reservoir 108 of tube 102 through lower orifice 118. Seal 120 extends along a longitudinal axis and includes a generally cylindrical outer surface 122. It is intended for outer surface 122 of seal 120 to form a fluidic seal with inner surface 106 of wall 104 so as to prevent fluid received in reservoir 108 from exiting reservoir 108 through lower orifice 118. In the depicted embodiment, lower surface 124 of seal 120 is generally coplanar with lower end 114 of wall 104.

Seal 130 is receivable in reservoir 108 of tube 102 through upper orifice 116. Seal 130 extends along a longitudinal axis and includes a generally cylindrical outer surface 132. It is intended for outer surface 132 of seal 130 to form a fluidic seal with inner surface 106 of wall 104 so as to prevent fluid received in reservoir 108 from exiting reservoir 108 through upper orifice 116. In the depicted embodiment, upper surface 134 of seal 130 is generally coplanar with upper end 112 of wall 104. It is contemplated to provide opening 136 through wall 104 at a location spaced from the intersection of outer surface 132 of seal 130 and inner surface 106 of wall 104 such that opening 136 communicates with reservoir 108. Upper portion 136a of opening 136 is generally coplanar with lower surface 138 of seal 130 to facilitate the flow of fluid into and out of reservoir 108, as hereinafter described.

Stanchion 140 projects from upper surface 134 of seal 130, for example, along the longitudinal axis of seal 130. However, stanchion 140 may project from other locations of or along other angles to upper surface 134 of seal 130. It is contemplated for upper surface 142 of stanchion 140 to lie in a plane generally parallel to and spaced from a plane containing upper end 112 of wall 104.

In order to fill device 100, device 100 is positioned within interior 74 of a capsule, e.g., first capsule 62, such that upper surface 142 of stanchion 140 is directed away from closed tip 76 of tapered portion 68 of first capsule 62. In addition, interior 74 of first capsule 62 is filled with a sufficient volume of a desired reagent 59 such that desired reagent 59 overlaps opening 136 in wall 104 of tube 102. Thereafter, lid 70 is moved to the closed position and first capsule 62 is deposited in a corresponding retainer 80 in centrifuge machine 60. With first capsule 62 received in a corresponding retainer 80 in centrifuge machine 60, centrifuge machine 60 is actuated so as to centrifuge first capsule 62 for a desired time (e.g., 30 seconds) at user selected revolutions per minute. As first capsule 62 (and hence, device 100) is centrifuged, a portion of reagent 59 in first capsule 62 is urged into corresponding reservoir 108 in device 100 such that the air, previously in reservoir 108, is expelled therefrom. The volume of fluid received in reservoir 108 of device 100 is controlled by the geometry and the volume of reservoir 108. By way of example, it is contemplated for each reservoir 108 to have a volume less than 10 microliters, and preferably, in the range of 0.01 microliters to 6 microliters. Reservoir 18 may have a diameter in the range of 50 micrometers to 1.5 millimeters and a length in the range of 1 millimeter and 15 millimeters. More specifically, it is contemplated for reservoir 108 to have a diameter of approximately 0.66 mm and a length of approximately 8 mm. However, other diameters and lengths are possible without deviating from the scope of the present invention. Once reservoir 108 is filled with reagent 59, as heretofore described, device 100 may be removed from capsule 62. This "prepackaged" device 100 may be transported to an end user. It is noted that small area of opening 136 in device 100 severely limits evaporation, and hence, mitigates the risk of evaporative loss of reagent 59 from reservoir 108.

In order to remove the reagent 59 from reservoir 108 of device 100, device 100 is positioned within a corresponding capsule, e.g., third capsule 82, such that upper surface 142 of stanchion 140 is directed towards, and preferably engages, closed tip 76 of tapered portion 68 of third capsule 82. Thereafter, lid 70 is moved to the closed position and third capsule 82 is deposited in a corresponding retainer 80 in centrifuge machine 60. With third capsule 82 received in retainer 80 in centrifuge machine 60, centrifuge machine 60 is actuated so as to centrifuge third capsule 82 for a desired time period (e.g., 30 seconds) at user selected revolutions per minute. As third capsule 82 (and hence, device 100) is centrifuged, reagent 59 in reservoir 108 of device 100 is urged from reservoir 108 through opening 136 and into corresponding interior 74 of third capsule 82. It can be appreciated that during the centrifugation process, stanchion 140 maintains opening 136 in device 100 in spaced relation to closed tip 76 of tapered portion 68 of third capsule 82 thereby assuring that all of the fluidic contents of reservoir 108 has been expelled from device 100 into corresponding interior 74 of third capsule 82, respectively. As this point, the nano- or micro-volumes of reagent 59 has been delivered to interior 74 of third capsule 82 and is accessible for downstream dilutions or applications.

Referring to FIGS. 11 and 12, a still further embodiment of a device to facilitate the prepackaging, handling and use of small volumes of fluids in accordance with the present invention is generally designated by the reference numeral 150. Device 150 includes lid 151, FIG. 11, having a generally planar plate 152 with first and second opposite sides 154 and 156, respectively. A plurality of cylindrical tubes 158 project from first side 154 of plate 152. By way of example,

in the depicted embodiment, a pair of spaced cylindrical tubes **158** project from first side **154** of plate **152**. However, additional cylindrical tubes **158** may project from first side **154** of plate **152** without deviating from the scope of the present invention. Each cylindrical tube **158** extends along a corresponding axis and is defined by wall **164** terminating at terminal edge **165**. Terminal edges **165** of walls **164** define openings **167** in cylindrical tubes **158**. Each wall **164** further includes a generally cylindrical inner surface **166** defining a reservoir **168** for receiving a volume of fluid therein, as hereinafter described, and a generally cylindrical outer surface **170**. While each tube **158** is depicted as being cylindrical in the drawing figures, it can be appreciated the other configurations are possible without deviating from the scope of the present invention. By way of example, it is contemplated for tube **158** to have a generally square or rectangular cross-section.

Device **150** further includes generally planar base **172** with first and second opposite sides **174** and **176**, respectively, FIG. **12**. A plurality of cylindrical recesses **178** are formed in first side **174** of base **172** and project from second side **176** of base **172**. By way of example, the number of spaced cylindrical recess **178** in base **172** is equal to the number of cylindrical tubes **158** projecting from first side **154** of plate **152** of lid **151**. However, additional cylindrical recess **178** may be formed in base **172** without deviating from the scope of the present invention. Each cylindrical recess **178** extends along a corresponding axis and is defined by wall **180**. Wall **180** includes a generally cylindrical inner surface **186** defining a reservoir **188** for receiving a volume of fluid therein, as hereinafter described, and a generally cylindrical outer surface **190**. While each recess **178** is depicted as being cylindrical in the drawing figures, it can be appreciated the other configurations are possible without deviating from the scope of the present invention. By way of example, it is contemplated for recess **178** to have a generally square or rectangular cross-section. First end **181** of each wall **180** intersects base **172** and defines a corresponding opening **183** in base **172** which communicates with reservoir **188** in a corresponding cylindrical recess **178**. Each opening **183** in base **172** is of sufficient dimension to allow a corresponding cylindrical tube **158** of lid **151** to pass therethrough into reservoir **188** of a corresponding cylindrical recess **178** in base **172**. Second end **192** of each wall **180** intersects a corresponding end wall **194** having an inner surface **196** partially defining reservoir **188**.

In order to fill lid **151** of device **150**, device **150** is positioned within interior **74** of a capsule, e.g. first capsule **62**, such that openings **167** in cylindrical tubes **158** are directed away from closed tip **76** of tapered portion **68** of first capsule **62**. In addition, interior **74** of first capsule **62** is filled with a sufficient volume of a desired reagent **59** such that desired reagent **59** overlaps openings **167**. Thereafter, lid **70** is moved to the closed position and first capsule **62** is deposited in a corresponding retainer **80** in centrifuge machine **60**. With first capsule **62** received in a corresponding retainer **80** in centrifuge machine **60**, centrifuge machine **60** is actuated so as to centrifuge first capsule **62** for a desired time period (e.g. 30 seconds) at user selected revolutions per minute. As first capsule **62** (and hence, device **100**) is centrifuged, a portion of reagent **59** in first capsule **62** is urged into corresponding reservoirs **168** in cylindrical tubes **158** through openings **167** such that the air, previously in reservoirs **168**, is expelled therefrom. The volumes of fluid received in reservoirs **168** of cylindrical tubes **158** are controlled by the geometry and the volume of reservoirs **168**. By way of example, it is contemplated for each

reservoir **168** to have a volume less than 10 microliters, and preferably, in the range of 0.01 microliters to 6 microliters. Reservoir **168** may have a diameter in the range of 50 micrometers to 1.5 millimeters and a length in the range of 1 millimeter and 15 millimeters. More specifically, it is contemplated for reservoir **168** to have a diameter of approximately 0.66 mm and a length of approximately 8 mm. However, other diameters and lengths are possible without deviating from the scope of the present invention.

Once reservoir **168** is filled with reagent **59**, as heretofore described, lid **151** of device **150** may be removed from capsule **62** and interconnected to base **172** so as to form device **150**. More specifically, to form device **150**, lid **151** is inserted into base **172** such that cylindrical tubes **158** of lid **151** are received in corresponding cylindrical recesses **178** in base **172**. As such, the "prepackaged" device **150** may be transported to an end user. It is noted that lid **151** interconnected to base **172**, openings **167** in cylindrical tubes **178** of lid **151** are spaced from corresponding inner surfaces **196** of end walls **194** partially defining reservoirs **188** or base **172**.

In order to remove the reagent **59** from reservoirs **168** of lid **151**, device **150**, namely, the lid **151** and base **172** combination is centrifuged. By way of example, lid **151** and base **172** combination may be positioned within a corresponding capsule, e.g. third capsule **82** such that outer surfaces **198** of end walls **194** of base **172** are directed towards closed tip **76** of tapered portion **68** of third capsule **82**. However, it can be appreciated that other arrangements for centrifuging lid **151** and base **172** combination are contemplated as being within the scope of the present invention. Thereafter, once lid **151** and base **172** combination is positioned within a corresponding capsule, e.g. third capsule **82**, lid **70** is moved to the closed position and third capsule **82** is deposited in a corresponding retainer **80** in centrifuge machine **60**. With third capsule **82** received in retainer **80** in centrifuge machine **60**, centrifuge machine **60** is actuated so as to centrifuge third capsule **82** for a desired time period (e.g. 30 seconds) at user selected revolutions per minute. As third capsule **82** (and hence, device **100**) is centrifuged, reagents **59** in reservoirs **168** of lid **151** are urged from reservoir **168** and into corresponding reservoirs **188** in cylindrical recesses **178** of base **172**. It can be appreciated that during the centrifugation process, the spacing between openings **167** in cylindrical tubes **178** of lid **151** and the corresponding inner surfaces **196** of end walls **194** partially defining reservoirs **188** of base **172** allows for all of the fluidic contents of reservoirs **168** to be expelled therefrom into corresponding reservoirs **188** in cylindrical recesses **178** of base **172**. After removal of lid **151** from base **172**, the nano- or micro-volumes of reagents **59** in reservoirs **188** in cylindrical recesses **178** of base **172** are accessible for downstream dilutions or applications.

It can be appreciated that the above descriptions of devices are merely exemplary of the present invention. Various modes of carrying out the invention are contemplated as being within the scope of the following claims particularly pointing out and distinctly claiming the subject matter, which is regarded as the invention.

We claim:

1. A device to facilitate the packaging and release of a volume of fluid, comprising:

an elongated tube having first and second ends and an inner surface defining a reservoir for receiving the volume of fluid, the reservoir having an orifice arrangement adjacent the first end of the tube and the inner surface being free of openings between the orifice arrangement and the second end of the tube; and

a stanchion having a first end operatively connected to the tube, the stanchion projecting away from the tube and terminating at a terminal second end which is maintained outside of the reservoir and is spaced from the first end of the tube. 5

2. The device of claim 1 wherein the reservoir has a volume less than 10 microliters.

3. The device of claim 2 wherein the reservoir has a volume in the range of 0.01 microliters to 6 microliters.

4. The device of claim 1 wherein the tube has a diameter 10 in the range of 50 micrometers to 1.5 millimeters.

5. The device of claim 1 wherein the tube has a length of 1 millimeter and 15 millimeters.

6. The device of claim 1 further comprising a seal closing off the second end of the tube. 15

7. The device of claim 6 wherein the first end of the stanchion is fixed to the seal.

8. The device of claim 1 wherein the second end of the tube is closed.

* * * * *