

(12) **United States Patent**
Iskandar et al.

(10) **Patent No.:** **US 10,709,879 B2**
(45) **Date of Patent:** **Jul. 14, 2020**

(54) **CEREBROSPINAL-FLUID SHUNT VALVE SYSTEM**

(71) Applicant: **Wisconsin Alumni Research Foundation**, Madison, WI (US)
(72) Inventors: **Bermans J. Iskandar**, Madison, WI (US); **Joshua Medow**, Verona, WI (US); **Christopher Luzzio**, Madison, WI (US); **John G. Webster**, Madison, WI (US); **Mehdi Shokouejad Maragheh**, Madison, WI (US); **Fa Wang**, Madison, WI (US); **Xuan Zhang**, Madison, WI (US)

(73) Assignee: **Wisconsin Alumni Research Foundation**, Madison, WI (US)

(*) Notice: Subject to any disclaimer, the term of this patent is extended or adjusted under 35 U.S.C. 154(b) by 502 days.

(21) Appl. No.: **15/473,126**

(22) Filed: **Mar. 29, 2017**

(65) **Prior Publication Data**
US 2018/0280670 A1 Oct. 4, 2018

(51) **Int. Cl.**
A61M 27/00 (2006.01)

(52) **U.S. Cl.**
CPC ... **A61M 27/006** (2013.01); **A61M 2202/0464** (2013.01); **A61M 2205/3331** (2013.01); **A61M 2210/0693** (2013.01)

(58) **Field of Classification Search**
CPC **A61M 27/006**
See application file for complete search history.

(56) **References Cited**

U.S. PATENT DOCUMENTS

6,024,340 A *	2/2000	Lazarus	F16K 31/004	251/129.06
6,248,080 B1 *	6/2001	Miesel	A61B 5/0215	600/311
7,951,105 B2	5/2011	Medow et al.			
8,876,744 B2	11/2014	Hsu et al.			
2011/0301575 A1 *	12/2011	Miesel	A61M 5/14276	604/891.1
2012/0302938 A1 *	11/2012	Browd	A61M 27/006	604/9
2012/0316492 A1 *	12/2012	Chappel	A61M 5/16881	604/67

OTHER PUBLICATIONS

Barry R. Lutz et al. "New and improved ways to treat hydrocephalus: Pursuit of a smart shunt." *Surgical neurology international* 4 (published online Mar. 19, 2013): pp. S38-S50. US.

* cited by examiner

Primary Examiner — Benjamin J Klein

(74) *Attorney, Agent, or Firm* — Boyle Fredrickson S.C.

(57) **ABSTRACT**

The present invention provides a cerebrospinal fluid shunt system that monitors the intracranial pressures over a portion of a monitoring cycle to calculate short intervals of drainage for every monitoring cycle necessary to produce the desired pressure correction. The system operates to significantly reduce the time during which draining occurs allowing tissue surrounding the catheter to rebound from the catheter holes returning to its normal position for a sufficient amount of time to recover its normal shape.

29 Claims, 7 Drawing Sheets

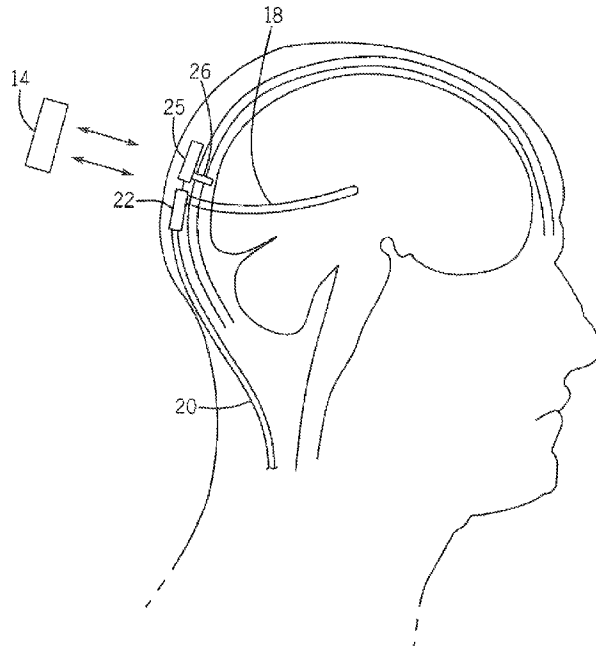

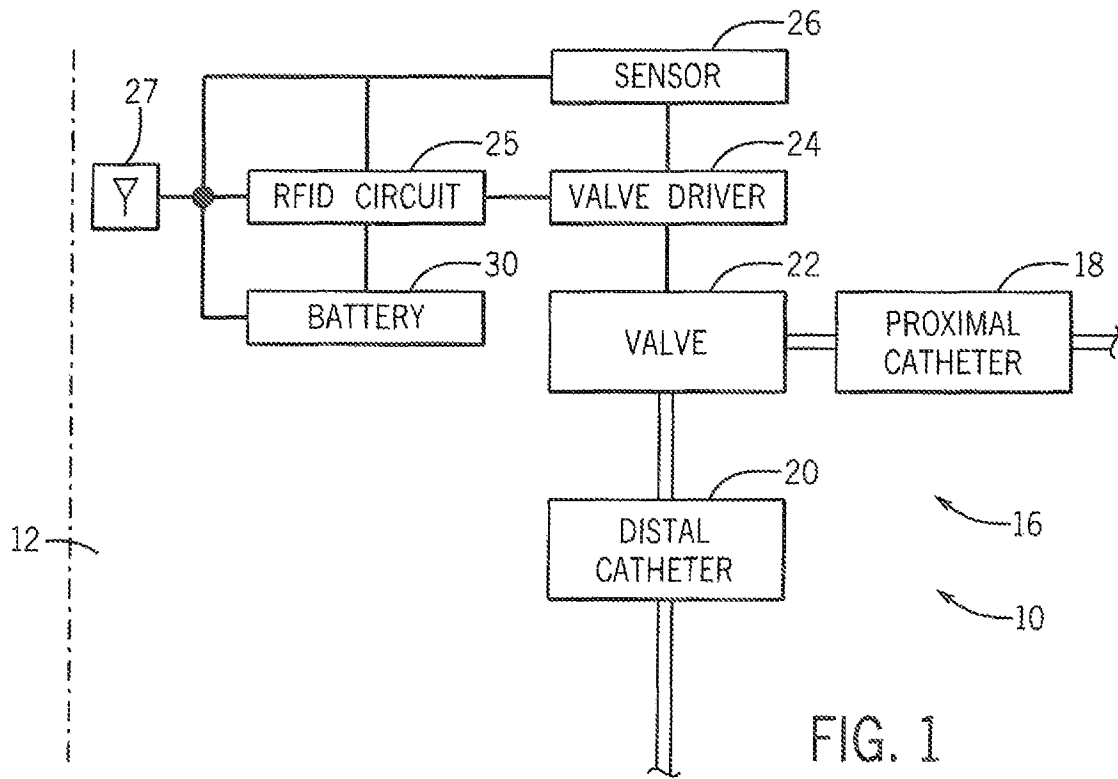

FIG. 1

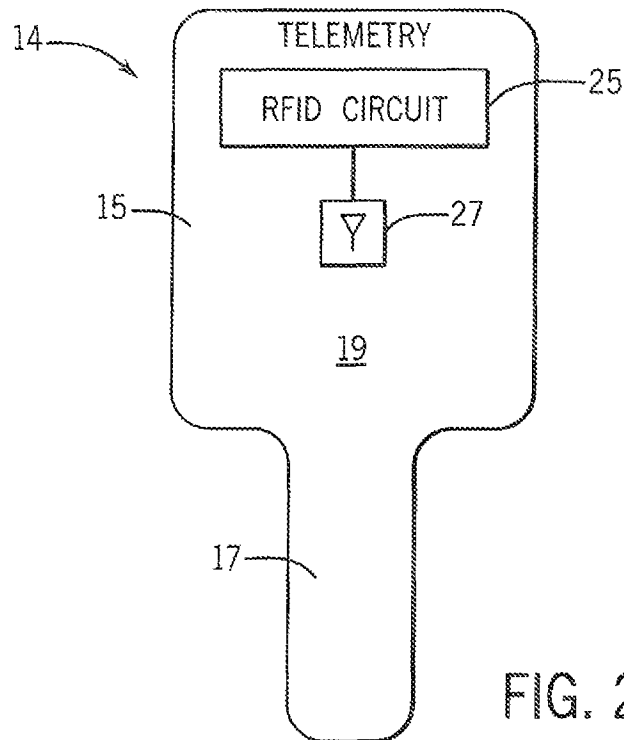

FIG. 2

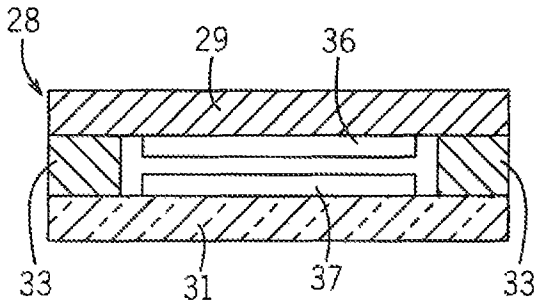

FIG. 3A

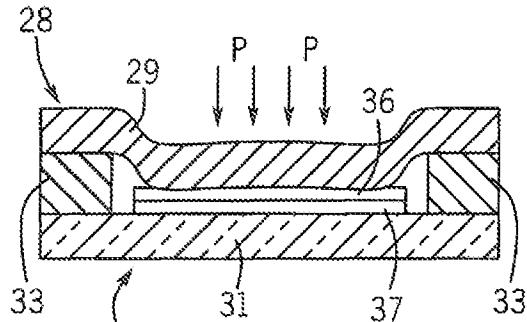

FIG. 3B

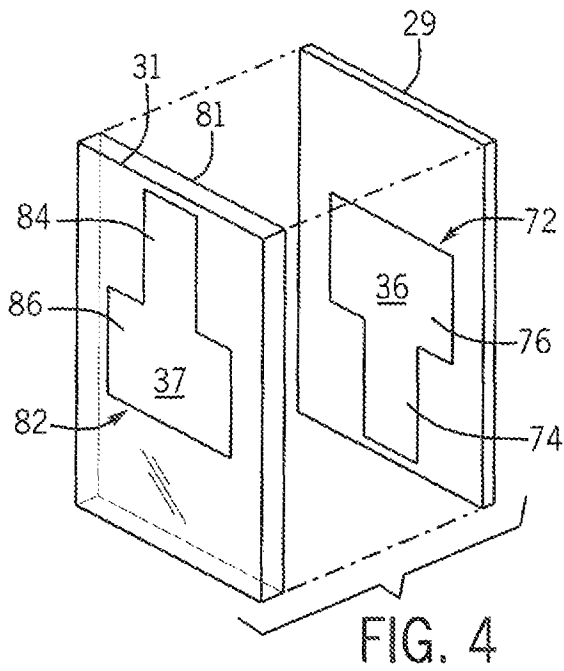

FIG. 4

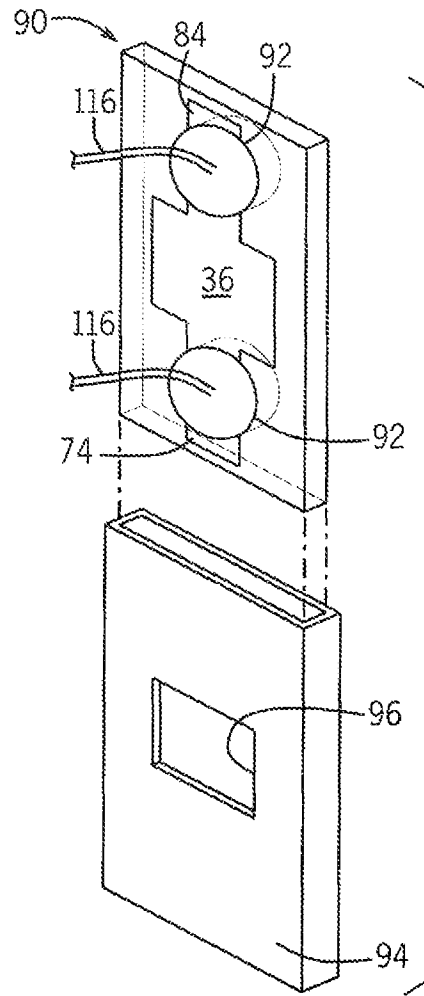

FIG. 5

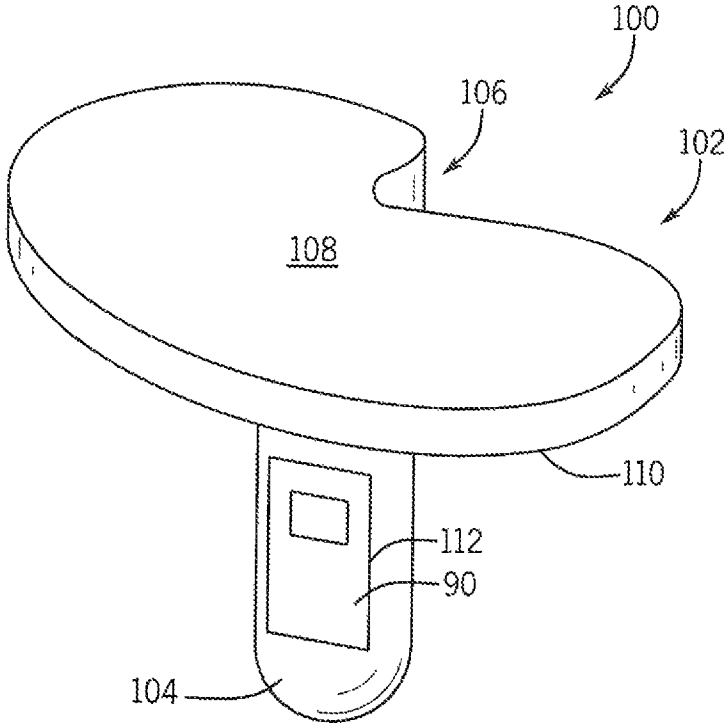

FIG. 6

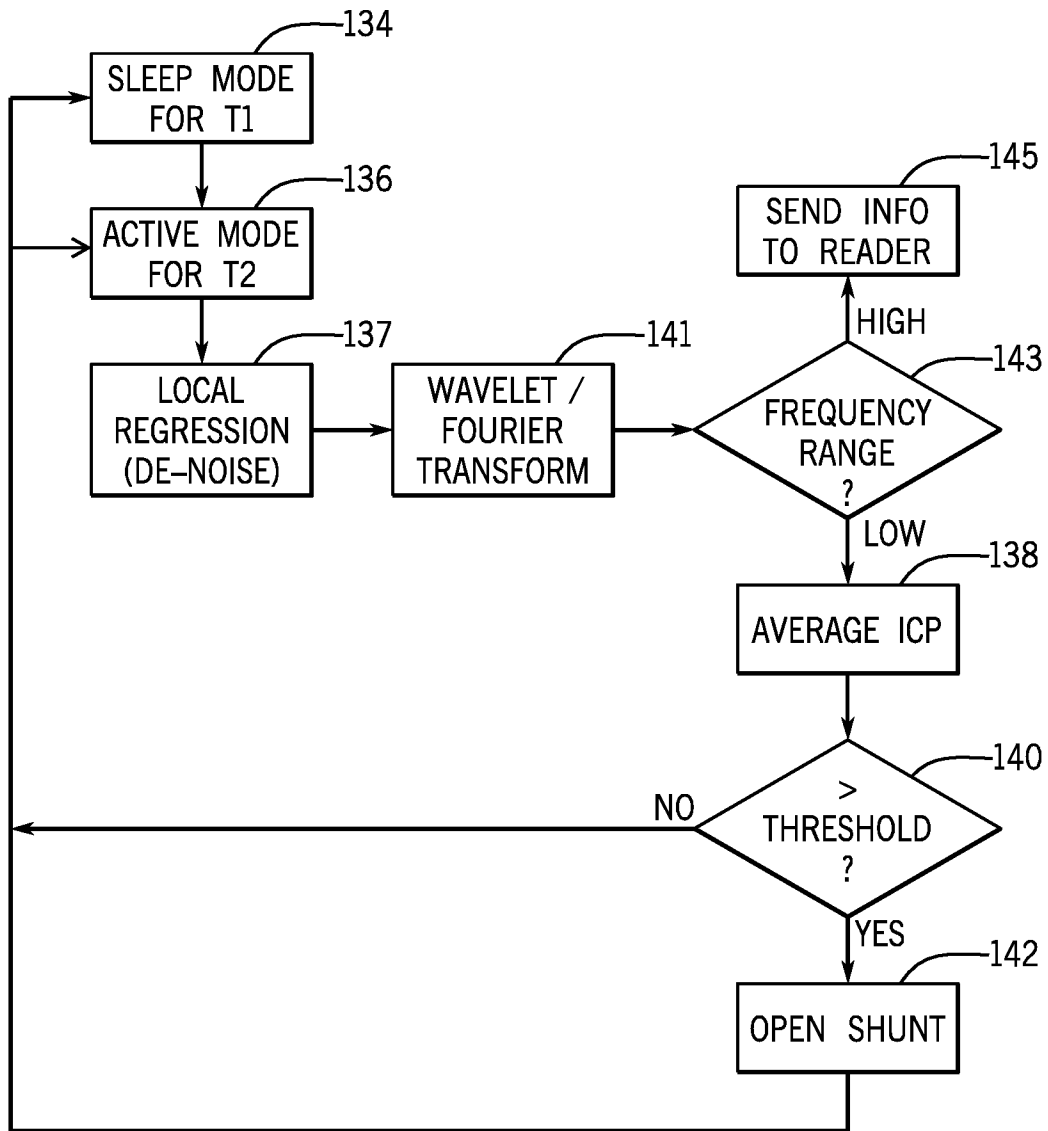

FIG. 7

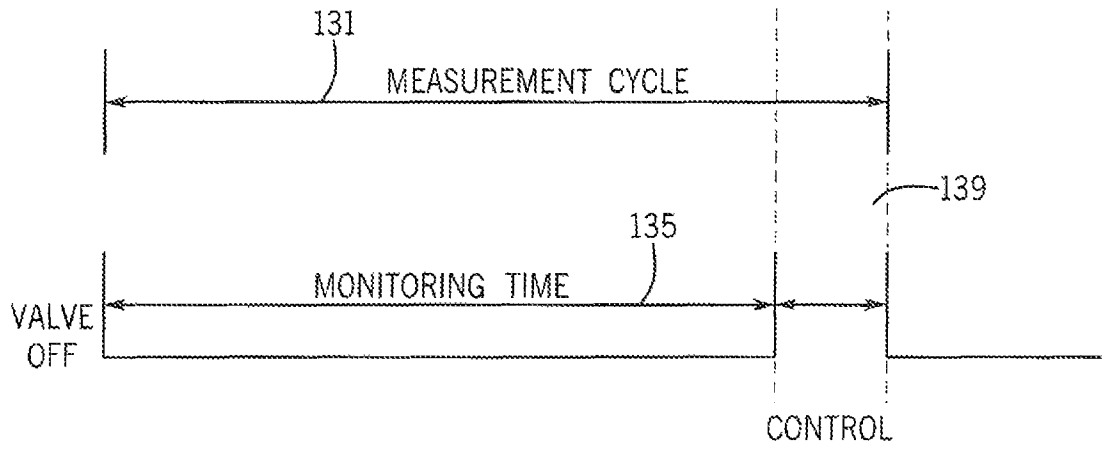

FIG. 8

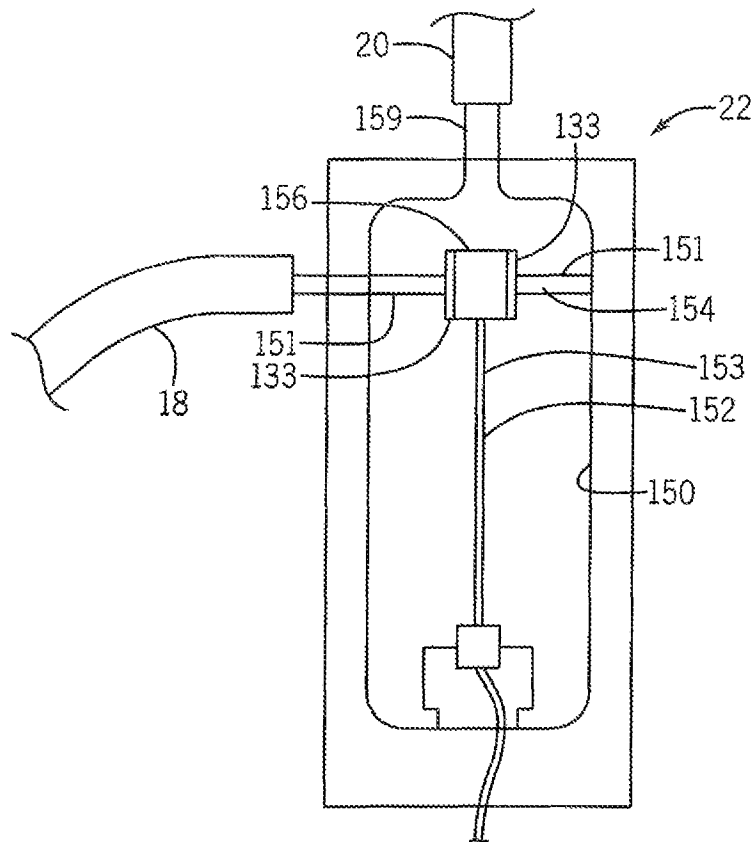

FIG. 9

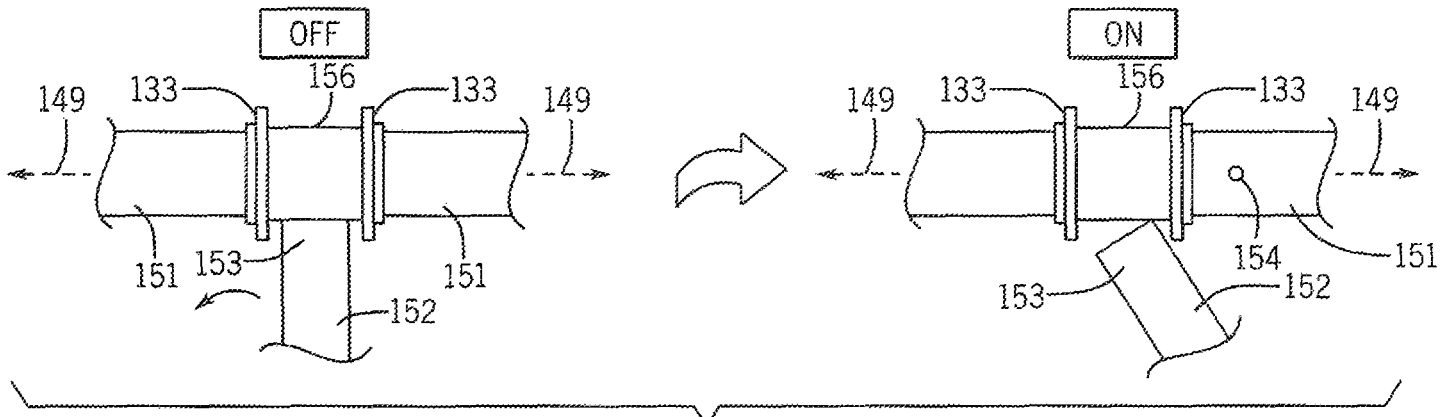

FIG. 10

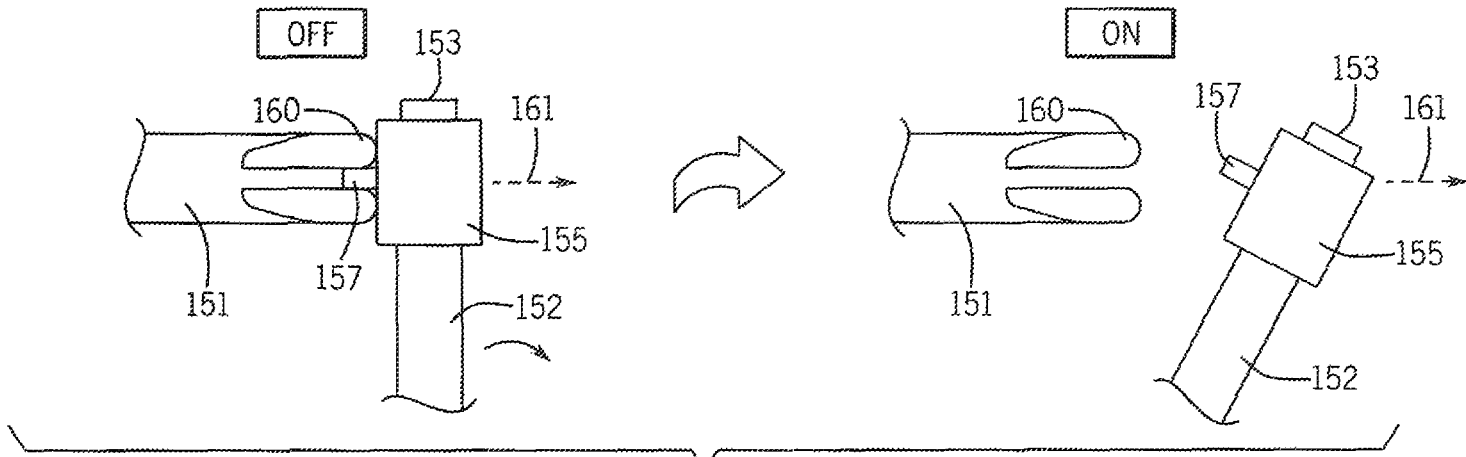

FIG. 11

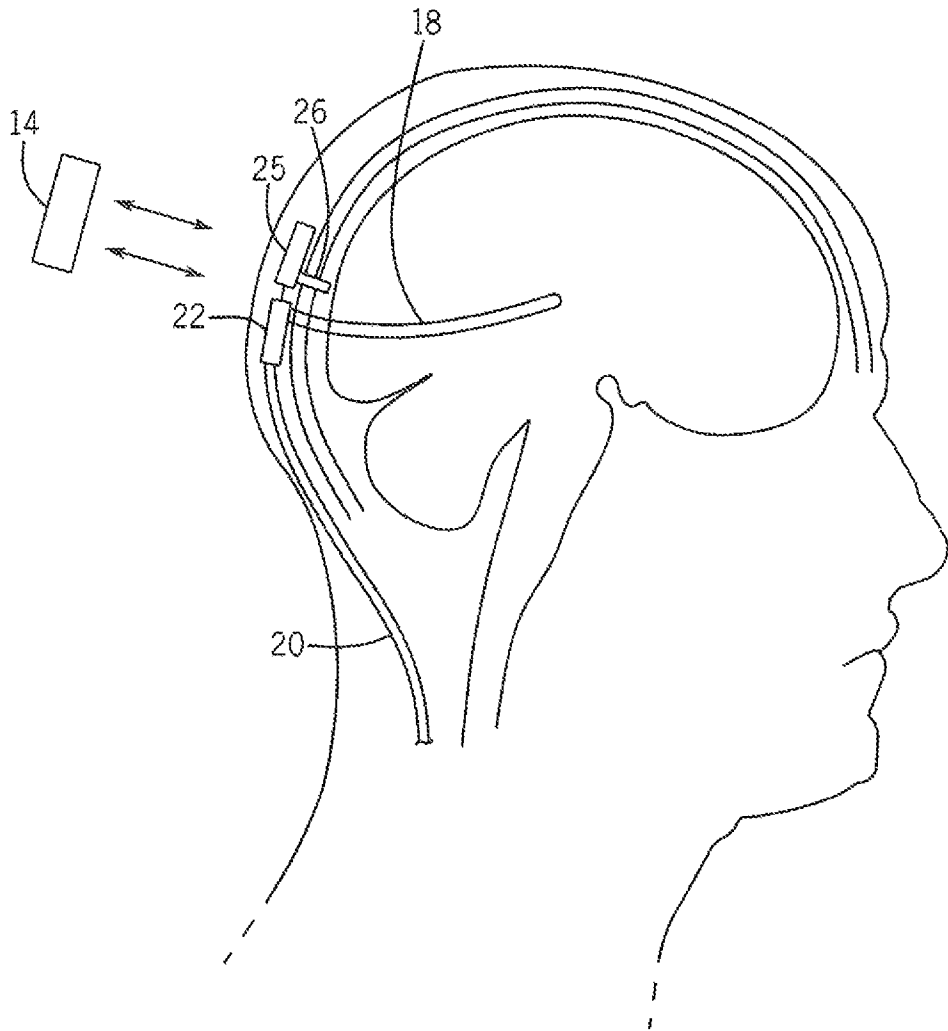

FIG. 12

1

CEREBROSPINAL-FLUID SHUNT VALVE SYSTEM

CROSS REFERENCE TO RELATED APPLICATIONS

--

STATEMENT REGARDING FEDERALLY SPONSORED RESEARCH OR DEVELOPMENT

--

BACKGROUND OF THE INVENTION

The present invention relates to neurosurgical devices used for treating hydrocephalus and, more specifically, to ventriculoperitoneal (VP) shunts that relieve pressure on the brain caused by excess fluid accumulation within the brain.

Hydrocephalus is a condition caused by an abnormal accumulation of cerebrospinal fluid (CSF) within the ventricles of the brain. Cerebrospinal fluid is produced in the choroid plexuses of the ventricles of the brain and circulates through the ventricular system of the brain to the subarachnoid spaces in the cranium and spine to be absorbed into the bloodstream. The fluid is used to surround the brain and spinal cord and acts as a protective cushion or buffer against injury. It also contains nutrients and proteins for nourishment and functioning of the brain while clearing away waste products.

Hydrocephalus occurs when there is an imbalance between the amount of CSF that is produced and the amount that is absorbed. When CSF builds up within the brain, it causes the ventricles to enlarge and increases the pressure inside the skull.

Hydrocephalus is typically treated through the surgical placement of a shunt system within the brain. The shunt system places a drainage tube between the brain's ventricles or the subarachnoid space and another body region, typically the abdominal cavity (or pleural cavity, heart atrium, and others), where the CSF can be absorbed. This creates an alternative route for removal of CSF buildup within the brain. Valves may be positioned within the shunt pathway to regulate flow based upon differential pressure, i.e., the pressure difference at the proximal catheter tip and the pressure at the drainage end.

Shunt failure is a very common complication requiring immediate shunt revision (the replacement or reprogramming of the pre-existing shunt). A shunt malfunction that does not receive immediate medical attention can be life-threatening or result in permanent neurologic injury. The shunt failure rate is relatively high (in the pediatric population, the shunt failure rate after one year is 40-50% and after five years is at nearly 100%) and it is not uncommon for patients to have multiple shunt revisions within their lifetime.

A leading cause of shunt failure is partial or complete blockage of the shunt. Both the proximal catheter placed in the brain and the distal catheter that provides the draining may become blocked. Typically when there is a blockage, the shunt must be replaced.

Under-drainage due to shunt blockage can cause the ventricles to increase in size and fail to remedy the symptoms of hydrocephalus. However, over-drainage is also undesired since it decreases the size of the ventricles and

2

creates slit like ventricles. Over-drainage has also been found to increase the likelihood of shunt blockages.

SUMMARY OF THE INVENTION

5

While the inventors do not wish to be bound by a particular theory, there is now evidence that blockage of the shunt may be caused by the continuous over-draining of CSF to relieve CSF buildup, even at low levels. Over time the ability of the tissue to rebound diminishes causing the tissue to be permanently deformed and lodged within the catheter holes. Tissue entering the catheter can tear or break off and create blockages within the catheter over time.

15

The present invention operates to significantly reduce the time during which draining occurs allowing tissue surrounding the catheter to rebound from the catheter holes returning to its normal position for a sufficient amount of time to recover its normal shape. Intracranial pressure (ICP) is the differential pressure between ICP and ambient pressure. Ambient pressure may be measured by an ambient pressure sensor in an external reader or implanted. Instead of allowing CSF to drain at a nearly constant flow rate, the present invention monitors the ICP over a portion of a monitoring cycle to calculate short intervals of drainage for every monitoring, cycle necessary to produce the desired, pressure correction. By continuously alternating between valve fully open and valve fully closed, the system can allow the brain tissue to retain its normal shape with reduced blockage.

20

Specifically, in one embodiment, the invention provides a cerebral shunt used to treat an abnormal accumulation of cerebrospinal fluid (CSF) in a brain of a patient, comprising: a catheter implanted within the brain of the patient with a proximal portion within the brain opposite a distal portion diverting CSF out of the brain to another region of the patient; a pressure sensor implanted within the brain of the patient and producing a signal representing an ICP; a valve that permits excess CSF to drain out of the brain through the catheter in an open position and prevents the excess CSF from passing out of the brain through the catheter in a closed position; and a valve driver receiving the signal representing the ICP controlling the valve to switch the valve between the open position and closed position in a cycle for successive cycles so that the relative time that the valve is in the open position versus the closed position is a function of ICP.

25

It is thus a feature of at least one embodiment of the invention to electrically control operation of the valve according to measured ICP to permit sophisticated control of the valve operation that can minimize long periods of drainage such as can cause tissue distortion.

30

The valve driver may be adapted to open the valve during each cycle for a period of time that is less time than a period of time that the valve is closed. The valve driver may be adapted to open the valve less than 10% of the time over each cycle. The valve driver may be adapted to open the valve less than 2% of the time over each cycle.

35

It is thus a feature of at least one embodiment of the invention to increase the time during which the valve is in a closed position to minimize tissue deformation.

40

The valve driver may be adapted to open the valve for a continuous period of time. The continuous period of time may be less than 5 seconds. The valve may be open for a period of time limited to a predetermined time permitting tissue surrounding the valve to be released from, the valve without irreversible shape change.

45

It is thus a feature of at least one embodiment of the invention to permit the tissue to recover between drainage sessions, preventing permanent deformation.

50

55

60

65

A controller may receive the signal from the pressure sensor over a period of time and averaging, the signal over the period of time. The period of time may be between 2 and 10 minutes.

It is thus a feature of at least one embodiment of the invention to provide continuous monitoring without the need for continuous drainage.

The valve driver may operate to attenuate an effect of sudden changes in the signal representing the ICP.

It is thus a feature of at least one embodiment of the invention to prevent sudden pressure changes or spikes (for example, caused by patient movement, sneezing, coughing) to cause over-drainage.

The pressure sensor may provide a pair of opposed conductive plates at least one plate flexing in response to ICP enabling circuitry detecting flexure according to at least one of varying resonant frequency, capacitance and piezo-resistance.

It is thus a feature of at least one embodiment of the invention to monitor an absolute pressure change to discount gravitational effects which influence pressure difference valves.

A biocompatible holder may comprise a disk having a broad face supporting an elongated tube extending downwardly therefrom and supporting the pressure sensor on a distal end of the tube.

It is thus a feature of at least one embodiment of the invention to allow for implantation of the pressure sensor to a desired depth within the skull while communicating with pressure sensor electronics outside of the skull.

The valve comprises a piezo bender actuator receiving electrical signals from the valve controller to be electrically actuated to reposition the piezo bender actuator to open or close the valve.

It is thus a feature of at least one embodiment of the invention to utilize piezoelectric qualities of materials in creating simplified electrically actuated valves.

The piezo bender actuator may be a cantilever repositioning to change a position of a collar extending around a tube having an orifice in series with the catheter to block the orifice. The piezo bender may be a cantilever repositioning to change a position of a plug removably insertable within an orifice of the catheter wherein the orifice permits CSF to drain.

It is thus a feature of at least one embodiment of the invention to utilize simple on-off valves.

A wireless transmitter may communicate the signal to an external wireless reader. The wireless transmitter may be an RFID device or other suitable wireless communication method.

It is thus a feature of at least one embodiment of the invention to permit external communication and control with the pressure sensing and valve control systems.

The present invention also provides a method of treating hydrocephalus where there is an abnormal accumulation of cerebrospinal fluid (CSF) in a brain of a patient comprising the steps of providing a cerebral shunt comprising a catheter having a proximal portion opposite a distal portion; a pressure sensor producing a signal representing an ICP; a valve limiting flow through the catheter between an open and closed position; implanting the proximal portion of the catheter within the brain of the patient and the distal portion outside the brain of the patient; implanting the sensor within the brain of the patient; and receiving, the signal representing the ICP controlling the valve to switch the valve between the open position and closed position in a cycle for succes-

sive cycles so that the relative time that the valve is in the open position versus the closed position is a function of ICP.

These particular objects and advantages may apply to only some embodiments falling within the claims and thus do not define the scope of the invention.

BRIEF DESCRIPTION OF THE FIGURES

FIG. 1 is a schematic of a cerebral shunt system of one embodiment of the present invention showing with a pressure sensor system installed within a patient;

FIG. 2 is an external telemeter device wirelessly communicating with the pressure sensor system within the patient;

FIG. 3A is a side elevation view of a pressure sensor system having upper and lower spiral metal coils/plates spaced apart in parallel alignment

FIG. 3B is the side elevation view of the pressure sensor system of FIG. 3A and showing a pressure applied to the top plate causing deflection of the upper metal coil/plate;

FIG. 4 is an exploded view of the pressure sensor having a first deflecting plate and a second non-moveable plate;

FIG. 5 is an exploded view of the plates of FIG. 4 bonded together and inserted within a protective sleeve and exposing the silicon membrane;

FIG. 6 is the bonded plates of FIG. 5 installed within a biocompatible holder;

FIG. 7 is a flow diagram of a valve control system;

FIG. 8 is a graph showing the measurement cycle of the valve control system over time;

FIG. 9 is a valve of one embodiment of the present invention installed within a housing;

FIG. 10 is an enlarged schematic of the valve of FIG. 9 showing a cantilevered piezo bender actuator sliding a collar to block or expose a tubular orifice permitting CSF flow into the housing;

FIG. 11 is a schematic of a valve of an alternative embodiment of the present invention showing a cantilevered piezo bender actuator having a plug to block or expose a tubular orifice permitting CSF flow into the housing; and

FIG. 12 is a simplified depiction of the cerebral shunt system installed within a skull of a patient.

DETAILED DESCRIPTION OF THE PREFERRED EMBODIMENT

Referring now to FIGS. 1 and 12, a cerebral shunt system 10 of the present invention may be partially implanted within a human patient 12. The cerebral shunt system 10 may include embedded devices 16 installed beneath the scalp and/or skull 13 of the human patient 12 communicating with an external reader or telemeter device 14 to be discussed below.

The embedded devices 16 assist with drainage of excess cerebrospinal fluid (CSF) surrounding the brain of the patient 12. The CSF may be drained from within the brain to another location within the patient's body, such as the abdominal cavity, peritoneal cavity, pleural cavity, or heart, able to absorb the excess CSF.

The embedded devices 16 include a proximal catheter 18 that may be surgically implanted in the cranium or spine to approach the ventricle or other CSF space where CSF resides so that CSF may be drained from the patient's brain or spinal canal. The proximal catheter 18 may be closed at the tip but include a number of small drainage holes, approximately 1 mm in diameter, running along a length of the proximal catheter 18. The holes may be arranged in rows and are generally positioned at a distal end of the catheter

allowing the CSF to flow from the ventricles or subarachnoid space through the holes and into the proximal catheter 18. The CSF is drained from the brain's ventricles or the subarachnoid space by flowing through the proximal catheter 18 leading away from the brain. The proximal catheter 18 extends from the brain through a small hole in the skull 13 to the outside of the skull 13.

A distal catheter 20 fluidly communicates with the proximal catheter 18 and typically runs underneath the scalp of the patient 12 and to a drainage site such as the abdominal cavity, peritoneal cavity, pleural, cavity, or heart. The distal catheter 20 may have a closed tip and also contain a number of small drainage holes, approximately 1 mm in diameter, running along a length of the distal catheter 20. The holes may be arranged in rows and are mostly positioned at a distal drainage end of the catheter allowing the CSF to drain out of the distal catheter 20 into the drainage site. The catheter may be open ended with or without slits.

A valve 22 is located between the proximal catheter 18 and the distal catheter 20, facilitating the fluid communication therebetween and regulating the flow rate of CSF through the catheter system. In one embodiment of the present invention, the valve 22 may be installed outside the skull 13 of the patient 12 but underneath the skin of the patient 12 and coupling the proximal catheter 18 to the distal catheter 20. It is understood that the valve 22 may be positioned anywhere along the catheter system to regulate flow rate in a similar manner. For example, the valve 22 may be located at the proximal catheter 18, distal catheter 20, or anywhere between the two catheters.

Operation of the valve 22 may be controlled by a valve driver 24 in the form of a microcontroller providing an electrical drive signal to the valve 22 according to a valve control program 132. The valve control program 132 may be processed by a valve driver 24 determining whether the valve 22 should be open or closed according to a sensed ICP. The valve driver 24 may include a digital processor, electronic memory holding the valve control program 132, an electrical interface circuit for communicating between the valve driver 24 and other devices as is generally understood in the art. According to the valve control program 132, the valve driver 24 will send a signal to the valve 22 to open or close the valve 22 thus allowing CSF to flow out of the skull 13 of the patient 12 or not flow out of the skull 13 of the patient 12. For example, when the valve 22 is open, CSF may drain through the distal catheter 20 whereas when the valve 22 is closed, CSF is not drained through the distal catheter 20.

The ICP may be determined by a pressure sensor 26 (to be described in more detail below) implanted within the skull 13 of the patient 12, e.g., in the brain parenchyma. The pressure sensor 26 may sense an absolute ICP, or condition representative of pressure, and deliver that sensed signal to the valve driver 24.

The valve driver/microcontroller 24 may also communicate with an RFID circuit 25 (or other wireless communication method) providing two-way communication through an antenna 27 with a handheld telemeter device 14. The antenna 27 may also communicate with a battery system 30 providing power to the other elements of the embedded devices 16 using standard wireless power transmission techniques such as radio-frequency identification (RFID) and resonance based inductive coupling technology.

As noted above, and referring to FIG. 2, the cerebral shunt system 10 may also include an external reader such as a handheld telemeter device 14 that may be positioned outside the patient's skull 13 to receive ICP data from the pressure

sensor 26 and to program the valve control program 132 as well as to provide electrical charging current for batteries 30 communicating with the pressure sensor 26 and the valve driver 24.

In one embodiment, the telemeter device 14 may be a handheld wand having a base 15 attached to a handle 17 for gripping, where in use, the base 15 has a broad face 19 positioned in close proximity to the patient's skull 13 so that the telemeter device 14 may wirelessly communicate with the embedded devices 16 within the patient 12. The telemeter device 14, e.g., within the base 15 portion, may contain an antenna 27 to facilitate the wireless communication therebetween. In one embodiment, telemeter device 14 may make use of a standard RFID circuit 25 (or other wireless communication device) for communicating with the RFID circuit 25 (or other wireless communication device) of the embedded devices 16 such as may communicate with the valve driver 24.

The telemeter device 14 may connect to a computer (e.g., PC or laptop) through an electrical conductor, such as a USB cable. Physicians may control the cerebral shunt system 10 on a Graphical User Interface (GUI) of the computer to set parameters or thresholds for the valve, as will be further discussed below.

It is understood that the telemeter device 14 may communicate with the embedded devices 16 through a wired or wireless connection and instead of being an external device, the telemeter device 14 may also be implanted or embedded device within the patient 12.

Sensing System

Referring now to FIGS. 3A and 3B, the pressure sensor 26 may include a housing 28 having a deformable upper plate 29 opposite and substantially parallel to a non-deformable lower plate 31. The upper plate 29 and lower plate 31 are held in separation by standoffs 33 extending at the outer edges between the two plates which seal between the upper plate 29 and lower plate 31 at a predetermined pressure for example atmospheric pressure or vacuum. The lower surface of the upper plate 29 and upper surface of the lower plate 31 support two oppositely disposed metal electrodes 36, 37 in parallel separation to each other. The metal electrodes 36, 37 may be made of copper, silver gold, or a material which may elastically deform with deformation of the upper plate 29.

When pressure (P) is applied to the upper plate 29 due to increased ICP caused by CSF buildup, the upper metal electrode 36 (center diaphragm) bends toward the lower metal electrode 37. In response to the physical repositioning of the upper metal electrode 36 with respect to the lower metal electrode 37, the capacitance between the upper metal electrode 36 and lower metal electrode 37 changes. This variation may be detected by a capacitive sensing routine executed by the valve driver 24 for example such as measures a change of charging time of the capacitance or a change in frequency when the capacitance is made part of a tuned resonant circuit.

The change in capacitance for small deflections may be proportional or otherwise functionally related to the applied ICP on the center diaphragm thus an ICP can be calculated.

Referring now to FIG. 4, in one embodiment of the pressure sensor 26 the upper plate 29 may be made of a thin silicon membrane. The first plate 29 contains a T-shaped well 72 extending within the upper plate 29 for supporting a similarly shaped diaphragm or metal electrode 36 that deforms under pressure. The T-shaped well 72, and correspondingly the metal electrode 36, has a vertical channel or

stem **74** of the T extending downward from a middle of the upper plate **29** toward a bottom of the upper plate **29** and a horizontal arm **76** extending across the top of the stem **74** forming the top of the T. The horizontal arm **76** is rectangular and is substantially centered within the upper plate **29** to define a center diaphragm. The metal electrode **36** fits within the T shaped well **72** and has a substantially identical shape as the T-shaped well **72** and fitting therein so as to fully encompass the T-shaped well **72**.

The non-deformable lower plate **31** may be a thick glass plate providing a “ground plane” that does not deform under ICP. A front side **81** of the plate **31** supports an electrode **37** in a similar manner as the upper plate **29**. The second plate **31** may contain an upside down T-shaped well **82** supporting the electrode **37** but not necessarily extending all the way through the glass plate but just at a surface. The T-shaped well **82**, and correspondingly the electrode **37**, has a vertical channel or stem **84** of the T extending upward from a middle of the plate toward a top of the second plate **31** and a horizontal arm **86** extending across the bottom of the stem **84** at the bottom of the upside down T. The horizontal arm **86** is rectangular and substantially centered within the second plate **31** to correspond in relative position with the horizontal arm **76** of the first plate **29**. The T-shaped well **82** carries the T-shaped electrode **37** having a substantially similar shape as the T-shaped well **82** and fitting therein so as to fully encompass the T-shaped well **82**.

Referring now to FIG. 5, the plate **29** is bonded to the front side **81** of the second plate **31** to create a bonded plate **90**. When the first plate **70** and second plate **31** are bonded together, the plates **29** and **31** are aligned such that the horizontal arms **76**, **86** of the first plate **29** and second plate **31** overlap and align such that the center diaphragms of the metal electrodes **36** and **37** are positioned in substantially parallel separation to create what is known as a parallel plate capacitor arrangement. The metal plates **29**, **31** may be separated by a vacuum to prevent electric transfer between the plates.

As shown, in the bonded plate **90**, holes **92** may be drilled through the bonded plate **90** within the vertical stem **74** of the T of the first plate **29** and vertical stem **84** of the T of the second plate **31** respectively so that each metal plate **36** and **37** may be electrically communicated with through wires **116**.

The bonded plate **90** may be covered by a protective sleeve such as parylene or silastic **94** having a front, back, and side walls corresponding with the walls of the bonded plate **90** and slid over the bonded plate **90** to provide a protective layer to the bonded plate **90**. The sleeve **94** includes a rectangular opening **96** allowing the horizontal arm **76** (center diaphragm) of the first plate **70** to be exposed to an applied ICP.

ICP (P) may be applied to the metal diaphragm through the rectangular opening silicon membrane **96** of the sleeve **94** causing the metal plate **36** to deflect while the electrode **37** remains non-movable within the glass plate **31**. The deflection of the metal plate **29** varies a distance between the two metal plates **36** and **37** changing the capacitance when a voltage is applied. The voltage may be applied to the plates through wires **116** attached to the holes **92** allowing electricity to flow from the wires **116** to the conductive plates and allowing a capacitance to be recorded. Detection of the capacitance is proportional to the applied ICP on the center diaphragm thus an ICP may be calculated.

Referring to FIG. 6, the bonded plate **90** held within the sleeve **94** may be carried by a biocompatible holder **100** that is installed within the skull of the patient **12** to measure ICP

changes. The biocompatible holder **100** may include a disk **102** supporting a downwardly extending tube **104**.

The disk **102** may be circular in shape and flattened to provide a top surface **108** opposite a bottom surface **110** to fit a human skull shape. A perimeter of the disk **102** may include a U-shaped cutout **106**.

A tube **104** extends downwardly from the bottom surface **110** of the disk **102** providing an oblong support structure with a rounded tip for carrying the pressure sensor **26**, for example, the bonded plate **90**. The tube **104** may have a rectangular receiving socket **112** within an outer surface of the tube **104** for receiving the pressure sensor **26**. The receiving socket **112** may be sized to receive the pressure sensor **26** therein and may include fastening or bonding means to secure the pressure sensor **26** in place. The pressure sensor **26** is installed within the receiving socket **112** such that the center diaphragm of the pressure sensor **26** is exposed allowing ICP pressure to be applied thereon.

The electrical wires **116** coupled to the pressure sensor **26**, for example, to each plate **29**, **31** of the bonded plate **90**, may run from a distal end of the tube **104**, through the tube **104**, and to the disk **102** where the electrical components are held so as to communicate an electrical signal and a capacitance measurement. The electrical wires **116** may communicate with the valve microcontroller **24**, RFID circuit **25** (or other wireless communication device), and other electronics for transmission to and from the implanted or external RFID circuit **25** (or other wireless communication device).

In an alternative embodiment, it will be understood that the capacitance formed by the electrical plates **36** and **37** may be incorporated into an electrically resonant circuit that may be interrogated remotely, for example using wireless signals from the telemeter device **14** which by measuring the frequency of this circuit (in the manner of a grid dip meter) can determine the ICP. Thus the pressure sensor **26** may be used independently as an ICP sensor or may communicate with the valve controller **24** wirelessly. The resonant circuit may be formed in part by shaping the electrical plates **36** and **37** into, spiral coils acting both as antennas and inductors for the purpose of creating the resonant circuit. In this case the pressure sensor **26** does not need to be wired or powered by an external power source, instead relying upon an external reader to detect and respond to physical changes within the pressure sensor **26**.

In an alternative embodiment, the pressure sensor **26** may be a commercially available piezoresistive sensor, e.g., where a silicon diaphragm is exposed to the ICP. A silicon diaphragm is used in which an ICP pressure difference across the diaphragm leads to a change of resistivity which may be measured by the valve controller **24**. For example, the piezoresistive sensor may be Amphenol P330 series or All Sensors DS-0287 series, both of which are commercially available.

It is understood that the pressure sensor **26** may be biocompatible and MRI compatible and may be used in conjunction with a holder **100** that is also biocompatible and MRI compatible. The RFID (or other wireless communication device) circuit **25** and antenna **27** may be isolated by a magnetic switch or reed switch that when in the presence of a magnetic field, such as when within an MRI machine, the antenna **27** will disable. The magnetic switch opens the circuit in high magnetic fields in each orthogonal plane. This prevents overheating and overcharging of the system in magnetic environments. Alternatively, various voltage

threshold circuit such as back to back diodes or the like may be used to shunt the antenna 27 for example by detuning it.

Valve Control System

Referring now to FIGS. 7 and 8, the valve driver 24 executing the valve control program 132, may receive the electrical signal indicating an ICP measurement of the pressure sensor 26 wirelessly or through a wired connection. The ICP measurement may consist of pulse waveforms having up to five peaks for a single pulse. The first three peaks (P1, P2, P3) generally determine the main waveform called a "P wave". P1 is due to the arterial pulse, P2 is due to cerebral compliance, and P3 is due to closure of the aortic valve, which causes the dicrotic notch.

The valve microcontroller 24 operates a program 132 comprising a number of steps to be described. The program may operate a "sleep mode" whereby the control program 132 does not record the incoming ICP sensor signals as indicated by the process step 134. The sleep mode helps to conserve energy consumption and, battery life.

After a predetermined amount of time (T1) has passed or when a predetermined condition occurs, such as when the patient 12 moves or during certain times of the day, the program proceeds to an "active mode" during which the control program 132 executes a measurement cycle 131 during which it records the incoming ICP sensor signals during a monitoring time 135 (T2) to determine an ICP over a predetermined time period as indicated by the process step 136. For example the active mode may record the incoming ICP sensor signals during a monitoring time 135 (T2). In one embodiment, the monitoring time 135 may be for a five or ten minute period or a period between five and ten minutes.

During or after the monitoring time 135 (T2) has passed, the recorded data is, processed using de-noising and smoothing algorithms and techniques, for example, moving average, low pass filter, exponential smoothing, etc. In one embodiment, the algorithm is a local regression method as indicated by the process step 137. In one embodiment, the local regression algorithm assigns regression weights to the value within a dynamic range with a length chosen to be 5:

$$w_i = \left(1 - \left|\frac{x - x_i}{d(x)}\right|^3\right)^3$$

where x is the predicted value associated with the original signal data to be smoothed, x_i is the neighbor of x in the dynamic range, and $d(x)$ is half of the dynamic range length at the x -axis. Based on these weights, the weighted linear least-squares regression is performed. The regression uses a second degree polynomial.

It is understood that other filtering techniques, e.g., moving average, low pass filter, exponential smoothing, etc., may be applied to the recorded data to remove outlier data and/or noise. For example, the filtering techniques may be used to attenuate or remove spikes within the incoming ICP sensor signals, for example, when the patient 12 stands up or coughs.

After the signal de-noising step, a wavelet transform will be applied to the signal to get the frequency range of the signal as indicated by process step 141. The process then proceeds to process step 143 where the frequency range of the resulting signal is determined.

If the frequency range is a high frequency range, the signal information is outputted to the medical professional

for further evaluation as indicated by process step 145. For example, the high frequency may indicate a critical patient condition or system failure that requires human intervention. If the frequency range is a low frequency range (e.g., DC level), then the shunt will be controlled depending on the signal and proceed to averaging step 138.

As indicated by process step 138, when the frequency range is in the low frequency range, the filtered recorded data is averaged over the recording time period.

The averaged ICP is compared against a threshold value (TH) which may be set by the operator (for example, 12 mm Hg). If an average ICP pressure value is over the threshold value, it is considered "high" and requires CSF draining and if an average ICP pressure value is under the threshold value is considered "normal" or "low" and does not require CSF draining as indicated by process step 140. If the averaged ICP is above the threshold value, the process continues to step 142 to open the valve 22 for a short control time 139 (T3) depending on the amount of difference between the averaged ICP and the threshold value, allowing the CSF to drain for the short period of time and then re-closing the valve immediately after. In one embodiment, the control time 139 may be between two and five seconds. This functional relationship between the error between the averaged ICP and the threshold value may use a known control algorithm such as proportional/integral/derivative algorithms for stability. The process then loops back to sleep mode 134 or active mode 136. If the averaged ICP is within a predetermined acceptability zone of the threshold pressure, the process automatically loops back to sleep mode 134 or active mode 136 with the valve 22 remaining closed. If the process loops back to active mode, the incoming electrical signals are recorded for the next predetermined time period and the cycle is repeated. If the process loops back to sleep mode 134, the process remains dormant until the program proceeds to active mode.

The operator may determine the parameters (TH, T1, T2, T3) associated with the control program 132. These parameters may be, conveyed to the valve microcontroller 24 through the telemeter device 14 or may be preprogrammed into the device. For example the operator may determine when and how long the control system remains in sleep mode 134. The operator may also determine when the system proceeds to active mode 136. The operator may also determine the threshold value (step 140) and the amount of time the valve 22 is opened (step 142).

In an alternative embodiment of the present invention, instead of exceeding a pressure threshold level, the valve may open based upon a pressure elevation over time. For example, the pressure elevation may be determined by an accelerometer or altimeter used to measure changes in altitude, vertical velocities, or altitudes of the device above a fixed level. In this respect, the valve may open as a function of intracranial pressure elevation and time. The valve may close as a function of a lower intracranial pressure parameter.

A cycle may be defined as switching from a closed valve 22 to an open valve 22 for successive cycles. It is understood that the valve 22 remains closed for the majority of time of the cycle whereas the valve 22 is opened for only short periods of time within the cycle when a high ICP is detected. In one embodiment, the valve may be opened 2 to 3 seconds or less than five seconds. In this respect, drainage of the CSF occurs for only short periods of time, minimizing the possibility of over drainage and allowing the tissue surrounding the catheter to rebound from a deformed position within the holes of the catheter when the valve 22 is off (i.e., tissue

11

recovery period). The valve **22** may be opened for a period of time limited to a predetermined time permitting tissue surrounding the catheter to be release from the catheter without irreversible shape change. In one embodiment, the valve **22** may remain open for less than 25% of the cycle time or less than 10% of the cycle time or less than 2% of the cycle time.

Although the closed valve **22** may indicate zero flow, it may also mean low flow allowing the tissue to be released from the catheter. In this respect, the open valve **22** may indicate a flow rate that substantially holds the tissue in the holes of the catheter.

Electrically Actuated Valves

Referring now to FIGS. **9**, **10** and **11** the valve, microcontroller **24** may receive a signal from the pressure sensor **26**, through a wired or wireless communication, indicating an ICP signal. The valve microcontroller **24** then runs the valve control program **132** to determine whether the valve should be on or off. The on-off instruction is then sent to the valve driver **24** to regulate the valve **22** of the cerebral shunt system **10** between an on and off state.

In one embodiment of the present invention, the electrical signal causes a piezo bender actuator **152** to bend between a first position and a second position, opening and closing the valve **22**. The piezo bender actuator **152** may be a cantilevered finger having at least one piezoelectric layer of material permitting the finger to displace in at least one direction, for example, providing 1 to 2 mm displacement. The piezo bender actuator **152** may be made of a ceramic, crystal, composite material, or known piezoelectric material and include side surface, electrodes attached to electrical wires **116** that may communicate with the valve driver **24**.

Referring specifically to FIGS. **9** and **10**, the valve's on and off state may be actuated by an electrical signal delivered from the valve driver **24** to the valve **22** to electrically actuate the valve **22**.

The valve **22** may provide for an enclosed chamber **150** (as shown in FIG. **9**) communicating with the proximal catheter **18**. An inflow tube **151** spans the enclosed chamber **150** and passes through one wall of the chamber **150** to the distal catheter **20**. The proximal catheter **18** may be connected in series with the inflow tube **151** regulating CSF flow to a drain tube **159** connected in series to the distal catheter **20**. The transverse inflow tube **151** and drain tube **159** may be constructed of stainless steel and, may have a diameter less than the catheter **18**, **20** allowing the catheter **18**, **20** to couple to the tubes **151**, **159** by sliding thereover.

As seen best in FIG. **10**, the inflow tube **151** has a small orifice **154** normally covered by a blocking collar **156** that prevents flow between the proximal catheter **18** and distal catheter **20** (for example, prevents flow from the orifice **154** into the chamber **150** and to the drain tube **159**).

A piezo electric bender **152** is fixed within the chamber **150** and extends in cantilevered fashion between bender guides **133** which allow the piezo electric bender **152** to slide the collar **156** along the inflow tube **151** in order to open and close the orifice **154**. The piezo bender actuator **152** extends toward the transverse inflow tube **151** and is displaced in one direction along axis **149** when a voltage is applied and in an opposite direction along axis **149** when a second voltage is applied.

When the piezo bender actuator **152** is in a first closed position, the collar **156** is in a position whereby the collar **156** covers the orifice **154** preventing CSF to drain from the inflow tube **151**. When the piezo bender actuator **152** is in a

12

second open position, the collar **156** is in a position whereby an orifice **154** of the transverse inflow tube **151** is exposed allowing CSF to drain from the transverse inflow tube **151**. It is understood that various gaskets or other sealing means may be used to prevent leakage.

Referring now to FIG. **11**, in an alternative embodiment of the present invention, the valve **22** may receive CSF from the proximal catheter **18** through an inflow tube **151** in a similar manner. The valve **22** may control flow from the inflow tube **151** to a drain tube **159** in series with the distal catheter **20** permitting CSF to drain.

The valve **22** may provide a housing with a chamber (FIG. **9**) supporting the inflow tube **151** and having an orifice **154** extending along an axis **161** used to drain CSF to the drain tube **159**. The housing may support a piezo bender actuator **152** defined by a cantilevered finger supported at one end and unrestricted on the opposite end **153** to become displaced in one direction substantially along axis **161** when a voltage is applied and in the opposite direction substantially along axis **161** when a second voltage is applied.

The free end **153** of the piezo bender actuator **152** may include a polymer gasket material **155** wrapped around the free end **153** and also including a flexible pin **157** extending from the gasket material **155** toward the orifice **154** substantially along axis **161** when displaced. The flexible pin **157** is sized and positioned to fit within the orifice **154** so as to plug the orifice **154** preventing the flow of CSF there-through.

When the piezo bender actuator **152** is in a first closed position, the free end **153** is positioned toward the orifice **160** and the pin **157** is plugged within the orifice **160** preventing CSF to drain from the inflow tube **151**. When the piezo bender actuator **152** is in a second open position, the free end **153** is positioned away from the orifice **160** and the orifice **160** is unblocked allowing CSF to drain from the inflow tube **151**.

It is understood that many types of electrically actuated valves **22** may be used in conjunction with the present invention for regulating the flow rate of CSF out of the brain and into a drainage site. While the valve **22** is generally described as an on-off valve it is understood that the valve **22** may also regulate the flow rate (varied flow rate above 0) when in the on position.

Certain terminology is used herein for purposes of reference only, and thus is not intended to be limiting. For example, terms such as "upper", "lower", "above", and "below" refer to directions in the drawings to which reference is made. Terms such as "front", "back", "rear", "bottom" and "side", describe the orientation of portions of the component within a consistent but arbitrary frame of reference, which is made clear by reference to the text and the associated drawings describing the component under discussion. Such terminology may include the words specifically mentioned above, derivatives thereof, and words of similar import. Similarly, the terms "first", "second" and other such numerical terms referring to structures do not imply a sequence or order unless clearly indicated by the context. When elements are indicated to be electrically connected, that connection may be direct or through an intervening conductive element.

When introducing elements or features of the present disclosure and the exemplary embodiments, the articles "a", "an", "the" and "said" are intended to mean that there are one or more of such elements or features. The terms "comprising", "including" and "having" are intended to be inclusive and mean that there may be additional elements or features other than those specifically noted. It is further to be

understood that the method steps, processes, and operations described herein are not to be construed as necessarily requiring their performance in the particular order discussed or illustrated, unless specifically identified as an order of performance. It is also to be understood that additional or alternative steps may be employed.

It is specifically intended that the present invention not be limited to the embodiments and illustrations contained herein and the claims should be understood to include modified forms of those embodiments including portions of the embodiments and combinations of elements of different embodiments as come within the scope of the following claims. All of the publications described herein, including patents and non-patent publications, are hereby incorporated herein by reference in their entireties.

We claim:

1. A cerebral shunt used to treat an abnormal accumulation of cerebrospinal fluid (CSF) in a brain of a patient, comprising:

a catheter adapted for implantation within the brain of the patient with a proximal portion within the brain opposite a distal portion diverting CSF out of the brain to another region of the patient;

a pressure sensor adapted for implantation within the brain of the patient and to produce a signal representing an intracranial pressure;

a valve connected to the catheter to conduct excess CSF to drain out of the brain through the catheter in an open position and to prevent the excess CSF from passing out of the brain through the catheter in a closed position; and

a valve driver control circuit communicating with the pressure sensor and the valve and operating to receive the signal representing the intracranial pressure and to control the valve to switch the valve between the open position and closed position in a cycle for successive cycles according to the signal representing the intracranial pressure and providing a measure of intracranial pressure so that the valve is opened at a first time when the measure of intracranial pressure is above a threshold value and the valve is closed at a second time following the first time while the measure of intracranial pressure still remains above the threshold value and to repeat an opening and closing of the valve while the measure of intracranial pressure remains above the threshold value;

wherein the valve comprises a piezo bender actuator receiving electrical signals from the valve controller to be electrically actuated to reposition the piezo bender actuator to open or close the valve; and

wherein the piezo bender actuator is a cantilever repositionable to change a position of a collar extending around a tube having an orifice in series with the catheter to block the orifice.

2. The cerebral shunt of claim 1 wherein the valve driver is adapted to open the valve during each cycle for a period of time that is less time than a period of time that the valve is closed.

3. The cerebral shunt of claim 2 wherein the valve driver is adapted to open the valve less than 10% of a total period of time of each cycle.

4. The cerebral shunt of claim 3 wherein the valve driver is adapted to open the valve less than 2% of a total period of time of each cycle.

5. The cerebral shunt of claim 2 wherein the valve driver is adapted to open the valve for a continuous period of less than 5 seconds.

6. The cerebral shunt of claim 1 wherein the valve driver is adapted to open the valve for a period of time limited to a predetermined time permitting tissue surrounding the catheter to be released from the catheter without irreversible shape change.

7. The cerebral shunt of claim 1 wherein the valve driver control circuit is a controller receiving the signal from the pressure sensor over a period of time and averaging the signal over the period of time.

8. The cerebral shunt of claim 7 wherein the valve driver operates to attenuate an effect of sudden changes in the signal representing the intracranial pressure.

9. The cerebral shunt of claim 7 wherein the valve driver is adapted to receive a signal from an ambient pressure sensor in an external reader.

10. The cerebral shunt of claim 9 wherein the external reader is adapted to receive user defined valve parameters and send the valve parameters wirelessly to the valve driver.

11. The cerebral shunt of claim 7 wherein the period of time is between 5 and 10 minutes.

12. The cerebral shunt of claim 1 wherein the pressure sensor provides a pair of opposed conductive plates, at least one plate flexing in response to intracranial pressure circuitry detecting flexure according to at least one of varying resonant frequency, capacitance and piezo-resistance.

13. The cerebral shunt of claim 1 further comprising a biocompatible holder comprising a disk having a broad face supporting an elongated tube extending downwardly therefrom and supporting the pressure sensor on a distal end of the tube.

14. The cerebral shunt of claim 1 further comprising a wireless transmitter adapted to communicate the signal to an external wireless reader.

15. The cerebral shunt of claim 14 wherein the wireless transmitter is a RFID device.

16. The cerebral shunt of claim 1 wherein the valve is adapted to open as a function of intracranial pressure elevation and time, and the valve is adapted to close based on a low intracranial pressure user defined parameter.

17. The cerebral shunt of claim 1 wherein the valve driver is adapted to open the valve during each cycle for a period of time that is a function of the measure of intracranial pressure.

18. A cerebral shunt used to treat an abnormal accumulation of cerebrospinal fluid (CSF) in a brain of a patient, comprising:

a catheter adapted for implantation within the brain of the patient with a proximal portion within the brain opposite a distal portion diverting CSF out of the brain to another region of the patient;

a pressure sensor adapted for implantation within the brain of the patient and to produce a signal representing an intracranial pressure;

a valve connected to the catheter to conduct excess CSF to drain out of the brain through the catheter in an open position and to prevent the excess CSF from passing out of the brain through the catheter in a closed position; and

a valve driver control circuit communicating with the pressure sensor and the valve and operating to receive the signal representing the intracranial pressure and to control the valve to switch the valve between the open position and closed position in a cycle for successive cycles according to the signal representing the intracranial pressure and providing a measure of intracranial pressure so that the valve is opened at a first time when the measure of intracranial pressure is above a thresh-

15

old value and the valve is closed at a second time following the first time while the measure of intracranial pressure still remains above the threshold value and to repeat an opening and closing of the valve while the measure of intracranial pressure remains above the threshold value;

wherein the valve comprises a piezo bender actuator receiving electrical signals from the valve controller to be electrically actuated to reposition the piezo bender actuator to open or close the valve; and

wherein the piezo bender is a cantilever repositionable to change a position of a plug removably insertable within an orifice of the catheter wherein the orifice permits CSF to drain.

19. The cerebral shunt of claim 18 wherein the valve driver is adapted to open the valve during each cycle for a period of time that is less time than a period of time that the valve is closed.

20. The cerebral shunt of claim 19 wherein the valve driver is adapted to open the valve less than 10% of a total period of time of each cycle.

21. The cerebral shunt of claim 20 wherein the valve driver is adapted to open the valve less than 2% of a total period of time of each cycle.

22. The cerebral shunt of claim 19 wherein the valve driver is adapted to open the valve for a continuous period of less than 5 seconds.

23. The cerebral shunt of claim 18 wherein the valve driver is adapted to open the valve for a period of time limited to a predetermined time permitting tissue surrounding the catheter to be released from the catheter without irreversible shape change.

24. The cerebral shunt of claim 18 wherein the valve driver control circuit is a controller receiving the signal from the pressure sensor over a period of time and averaging the signal over the period of time.

25. The cerebral shunt of claim 18 wherein the valve driver is adapted to open the valve during each cycle for a period of time that is a function of the measure of intracranial pressure.

26. A method of treating hydrocephalus where there is an abnormal accumulation of cerebrospinal fluid (CSF) in a brain of a patient comprising the steps of:

providing a cerebral shunt comprising

16

a catheter having a proximal portion opposite a distal portion;

a pressure sensor producing a signal representing an intracranial pressure;

a valve limiting flow through the catheter between an open and closed position;

implanting the proximal portion of the catheter within the brain of the patient and the distal portion outside the brain of the patient;

implanting the pressure sensor within the brain of the patient; and

receiving the signal representing the intracranial pressure to control the valve to switch the valve between the open position and closed position in a cycle for successive cycles according to the signal representing the intracranial pressure and providing a measure of intracranial pressure so that the valve is opened at a first time when the measure of intracranial pressure is above a threshold value and the valve is closed at a second time following the first time while the measure of intracranial pressure still remains above the threshold value and to repeat an opening and closing of the valve while the measure of intracranial pressure remains above the threshold value

wherein the valve comprises a piezo bender actuator receiving electrical signals from the valve controller to be electrically actuated to reposition the piezo bender actuator to open or close the valve; and

wherein the piezo bender actuator is a cantilever repositionable to change a position of (i) a collar extending around a tube having an orifice in series with the catheter to block the orifice or (ii) a plug removably insertable within an orifice of the catheter wherein the orifice permits CSF to drain.

27. The method of claim 26 further comprising the step of opening the valve during each cycle for a period of time that is less time than a period of time that the valve is closed.

28. The method of claim 26 further comprising the step of receiving the signal from the pressure sensor over a period of time and averaging the signal over the period of time.

29. The method of claim 26 wherein the catheter is in the ventricular or spinal compartment and drains to the abdomen or other body space.

* * * * *