



US 20200337889A1

(19) **United States**

(12) **Patent Application Publication**

**Brown et al.**

(10) **Pub. No.: US 2020/0337889 A1**

(43) **Pub. Date: Oct. 29, 2020**

(54) **COMPRESSIBLE VAGINAL PESSARY FOR TREATMENT OF STRESS URINARY INCONTINENCE**

(71) Applicant: **Wisconsin Alumni Research Foundation, Madison, WI (US)**

(72) Inventors: **Heidi W. Brown, Monona, WI (US); Rachel J. Craven, Madison, WI (US); Alexandra M. Hadyka, Selbyville, DE (US); Julia M. Handel, Madison, WI (US); Kathryn M. Hohenwalter, Brookfield, WI (US); Gloria E. Sarto, Madison, WI (US)**

(21) Appl. No.: **16/859,248**

(22) Filed: **Apr. 27, 2020**

**Related U.S. Application Data**

(60) Provisional application No. 62/839,029, filed on Apr. 26, 2019.

**Publication Classification**

(51) **Int. Cl.**  
*A61F 6/08* (2006.01)  
*A61L 27/16* (2006.01)  
(52) **U.S. Cl.**  
CPC ..... *A61F 6/08* (2013.01); *A61L 27/165* (2013.01)

(57) **ABSTRACT**

The present invention provides a vaginal pessary that offers mid-urethral support and is anchored proximate the cervix by a proximal annulus engaging opposing walls of the vagina and supporting a distal annulus engaging opposing walls of the vagina posterior to the mid-urethra. The proximal and distal annulus are joined by compressible cross rods to reduce a diameter of at least one of the proximal and distal annuli.

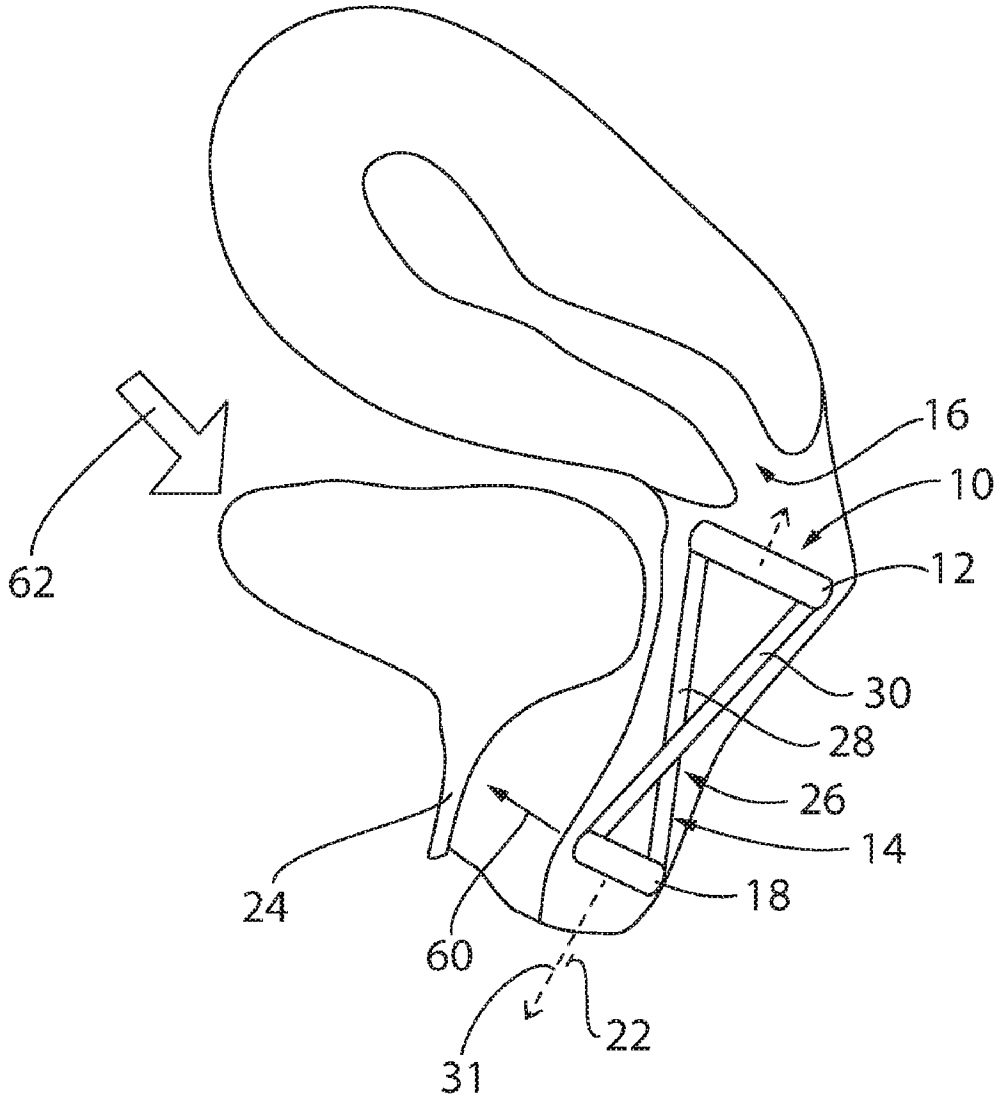

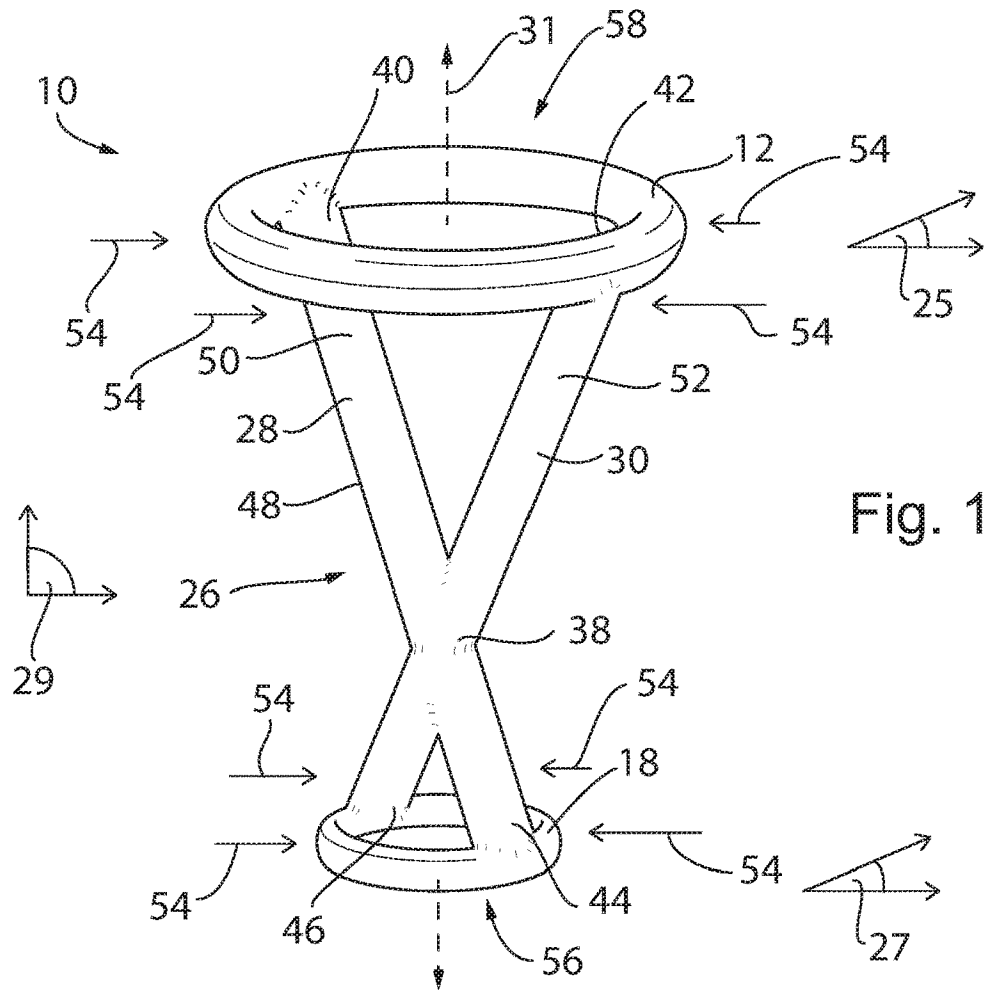

Fig. 1

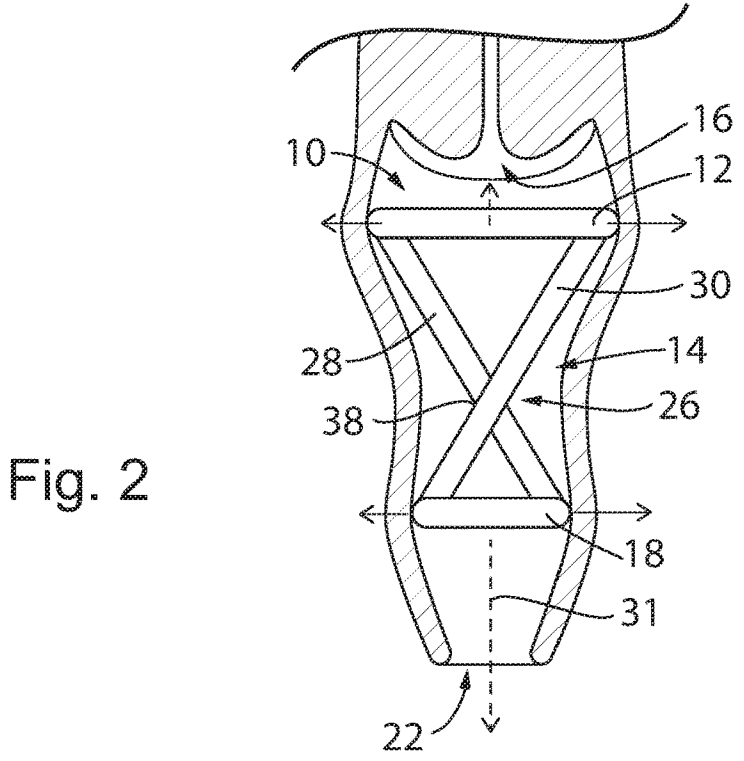

Fig. 2

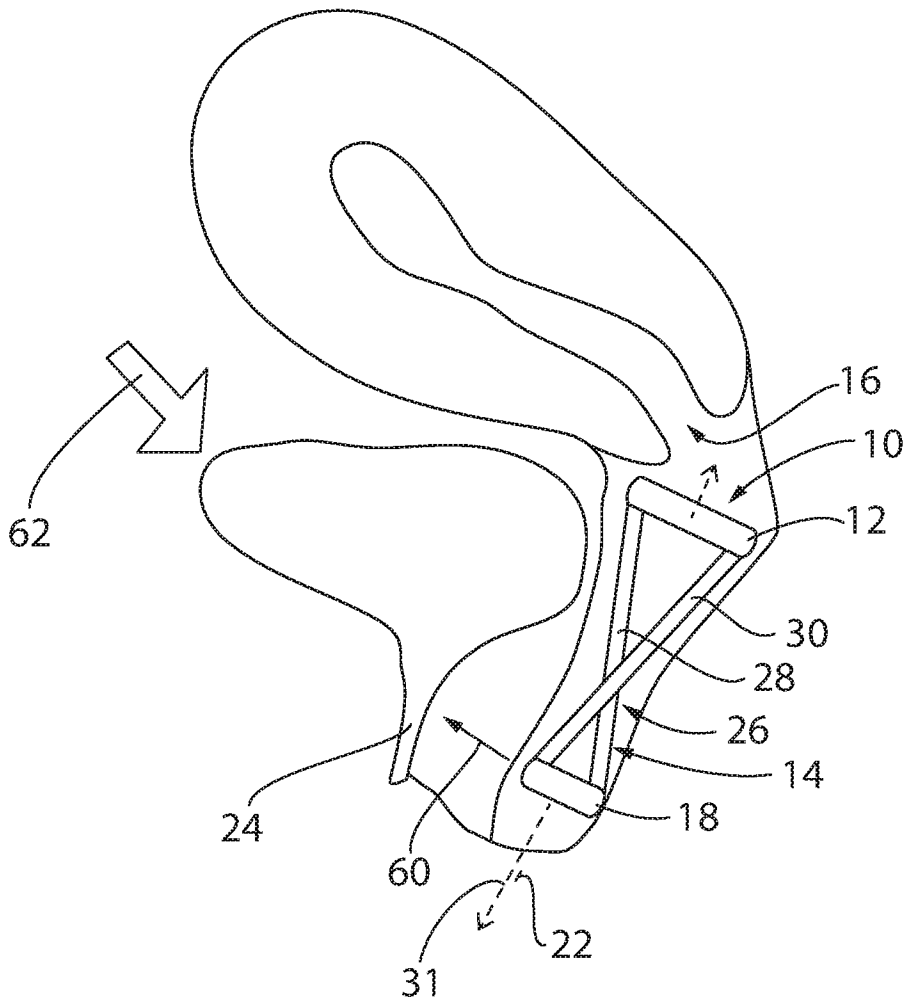

Fig. 3

**COMPRESSIBLE VAGINAL PESSARY FOR  
TREATMENT OF STRESS URINARY  
INCONTINENCE**

CROSS-REFERENCE TO RELATED  
APPLICATIONS

[0001] This application claims the benefit of U.S. Provisional Application No. 62/839,029, filed Apr. 26, 2019, and hereby incorporated by reference.

STATEMENT REGARDING FEDERALLY  
SPONSORED RESEARCH OR DEVELOPMENT

BACKGROUND OF THE INVENTION

[0002] The present invention relates to vaginal pessaries for treating stress urinary incontinence.

[0003] Accidental urinary leakage affects more than half of independent women aged 65 and older in the United States. Stress urinary incontinence is the most prevalent type of urinary incontinence, present in over 80% of urinary incontinence cases. Stress urinary incontinence is defined by leakage associated with activities that increase intra-abdominal pressure, such as when coughing, sneezing, and during physical activity. Pelvic floor muscle strengthening, vaginal pessaries, and mid-urethral sling surgery are common treatment options for those suffering from stress urinary incontinence.

[0004] Pelvic floor muscle strengthening exercises are done by flexing the muscles used to stop urination. When exercises are maintained, pelvic floor muscle strengthening exercises are shown to be effective in treating stress urinary incontinence in just over half of women in the short term. However, many women discontinue their exercises over time.

[0005] Pessaries are vaginally inserted devices that are used to treat pelvic organ prolapse as well as urinary incontinence. Current pessaries for treating urinary incontinence are commonly ring-shaped devices with a knob at the distal end, placed with the proximal end of the ring against the cervix or the apex of the vagina and the more distal end (with the knob) against the pubic symphysis on the anterior vaginal wall. The more distal end with the knob is intended to support the area beneath the bladder neck. Current vaginal pessaries operate on the belief that loss of support of the bladder neck contributes to the cause of stress urinary incontinence. Current pessaries are shown to improve the symptoms of about half of women.

[0006] Through a better understanding of the underlying pathophysiology of stress urinary incontinence, it has been found that support of the mid-urethra, not just the bladder neck, may be important for treating stress urinary incontinence. Mid-urethral sling surgery draws on this idea by using a synthetic mesh to provide “sling” support underneath the mid-urethra where the weakened pelvic floor muscles previously provided support. Mid-urethral sling surgery has proven to be the most effective treatment so far for treating stress urinary incontinence, resulting in improvement in over 90% of women who undergo the surgery.

[0007] Despite the success of mid-urethral sling surgery, the surgery may not be an available option to all women and others may not wish to undergo the invasive surgery.

SUMMARY OF THE INVENTION

[0008] The present inventors have recognized that it is possible to produce a vaginal pessary that offers appropriate mid-urethral support. The new vaginal pessary provides a larger proximal annulus that anchors the pessary device within the vagina toward the cervix and is separated in parallel planes by an X-shaped frame from a smaller distal annulus extending toward the opening of the vagina to be positionable posterior to the mid-urethra to provide posterior support behind the urethra.

[0009] It is thus a feature of at least one embodiment of the present invention to allow easy insertion and removal of the pessary from the vagina without physician assistance by placement of the distal annulus close to the vaginal opening whereby compression of the distal annulus by the patient compresses the entire width of the pessary.

[0010] It is also a feature of at least one embodiment of the present invention to prevent longitudinal movement of the pessary along an axis of the vagina by using a larger proximal annulus engaging the vaginal walls perpendicular to the axis to anchor the pessary to the vaginal walls.

[0011] In one embodiment, the present invention is a pessary device for treating stress urinary incontinence having a first annulus elastically deformable to bend inward and providing an outward radial force configured to engage opposing walls of the vagina; a second annulus elastically deformable to bend inward and providing an outward radial force configured to engage opposing walls of the vagina and having a diameter less than the first annulus; and first and second rods intersecting at a pivot point and having ends of the first and second rods separated by attachment to opposite ends of the first and second annulus, respectively, wherein the first and second rods are compressible toward each other about the pivot point to further reduce a dimension of at least one of the first and second connected annulus.

[0012] It thus a feature of at least one embodiment of the present invention to place sufficient localized pressure on the mid-urethra to prevent urine leakage associated with stress urinary incontinence.

[0013] A length of the first and second rods may be between 4 cm and 9 cm.

[0014] It thus a feature of at least one embodiment of the present invention to position the proximal ring near the cervix and the distal ring posterior to the mid-urethra in an average sized human patient's vagina.

[0015] A diameter of the first annulus may be between 3 cm and 6 cm and a diameter of the second annulus is between 1 cm and 3 cm.

[0016] It thus a feature of at least one embodiment of the present invention to anchor the proximal ring deeper within the vagina to prevent the pessary from becoming dislodged during user movement while the distal ring sits comfortably near the opening of the vagina where the ring may be easily reached by the patient.

[0017] The first and second annulus may provide a flexure reducing a diameter of the first and second annulus in at least one direction such that the first annulus and second annulus may be sized to be inserted into the vagina.

[0018] It thus a feature of at least one embodiment of the present invention to allow the pessary to be easily insertable by the patient without physician or medical professional intervention in an at-home environment and without having to go into a medical office or hospital.

[0019] The first and second annulus may be rings of silicone rubber. The rings may have a cross sectional thickness between 0.25 cm and 1 cm.

[0020] It thus a feature of at least one embodiment of the present invention to allow the biocompatible rings to be sterilizable for repeated use.

[0021] The first and second annulus may provide a flexure reducing a diameter of the pessary at least 50% under less than 40 Newton force.

[0022] It thus a feature of at least one embodiment of the present invention to permit older or weaker patients to compress the ring(s) of the device with a single hand for insertion and removal from the vagina.

[0023] The pivot point of the first and second rods may be closer to the second annulus than the first annulus.

[0024] It thus a feature of at least one embodiment of the present invention to utilize a double lever of the first class to produce greater compression of the larger proximal ring through a smaller compression on the smaller distal ring using a longer load arm of the proximal ring.

[0025] The first and second rods may be rigid wires coated with silicone rubber.

[0026] It thus a feature of at least one embodiment of the present invention to allow the elastic rods to quickly rebound after being compressed to stabilize the device within the vagina and to prevent sliding along the vagina.

[0027] The first and second rods may be compressible at least 50% toward each other under less than 40 Newton force.

[0028] It thus a feature of at least one embodiment of the present invention to produce a fulcrum at the intersection of the rods that allow the proximal and distal rings to compress about the fulcrum with minimal force by the patient.

[0029] In an alternative embodiment, the present invention is a method of treating stress urinary incontinence including the steps of: providing a pessary having a first annulus dimensioned to extend across opposing walls of a vagina opposite a second annulus dimensioned to extend across opposing walls of a vagina and having a diameter less than the first annulus, the first and second annulus joined by separated first and second ends of a pair of cross rods, respectively, intersecting at a pivot point and compressible toward each other to further compress at least one of the attached first and second annulus; compressing at least one of the first annulus, second annulus and pair of cross rods to reduce a width of the pessary to allow insertion of the pessary into the vagina; inserting the pessary such that the first annulus is proximate a cervix and the second annulus is proximate an opening of the vagina posterior to the mid-urethra; and releasing the at least one of the first annulus, second annulus and pair of cross rods to allow the first and second annulus to contact the opposing walls of the vagina.

[0030] The second annulus may be positionable posterior to the mid-urethra to provide an opposing force when pressure is applied to the mid-urethra.

[0031] Compression of the opposed ends of the pair of cross rods toward each other further compress the joined first and second annulus.

[0032] These particular objects and advantages may apply to only some embodiments falling within the claims and thus do not define the scope of the invention.

#### BRIEF DESCRIPTION OF THE DRAWINGS

[0033] FIG. 1 is a perspective view of a pessary of the present invention shown in partial phantom and providing an elastomeric first and second annulus supported coaxially in separate parallel planes by compressible cross bars having internal support wires;

[0034] FIG. 2 is a cross-section of the vagina taken along a coronal plane extending between a patient's anterior and posterior sides and showing the first annulus anchored to the inner walls of the vagina proximate the cervix to retain the second annulus in position proximate the opening of the vagina posterior to the mid-urethra; and

[0035] FIG. 3 is a cross-section of a vagina taken along a sagittal plane extending between a patient's left and right sides and showing the pessary inserted into the vagina with the first annulus positionable proximate the cervix and the second annulus positionable proximate the opening of the vagina, and the second annulus providing support to the mid-urethra in response to intra-abdominal pressures applied to the vaginal region.

#### DETAILED DESCRIPTION OF THE INVENTION

[0036] Referring now to FIGS. 1 through 3, a pessary 10 may include a large annulus 12 positionable desirably positionable proximate a proximal end of a vagina 14 toward a cervix 16 opposite a small annulus 18 desirably positionable proximate to the distal end of the vagina 14 toward an opening 22 of the vagina 14 and generally posterior to a midsection of the urethra 24. The large annulus 12 and the small annulus 18 may be supported coaxially in separated parallel planes 25, 27 by an X-shaped frame 26 lying generally within a plane 29 extending along an axis of separation 31 extending between the large annulus 12 and small annulus 18.

[0037] The X-shaped frame 26 has a first straight beam 28 intersecting a second straight beam 30. Opposed ends of the first straight beam 28 and second straight beam 30 are attached to the large annulus 12 at diametrically opposed locations and to the small annulus 18 at diametrically opposed locations, respectively, to space the large annulus 12 from the small annulus 18 along the axis of separation 31, which is perpendicular to the planes 25, 27 of the large annulus 12 and small annulus 18 to position the large annulus 12 and small annulus 18 at desired anatomical locations within the vagina 14 as further described below.

[0038] Referring now to FIG. 1, the X-shaped frame 26 may include the first straight beam 28 and the second straight beam 30 joined and intersecting and/or overlapping at a pivot point 38 forming a fulcrum, similar to a scissors, whereby the first straight beam 28 and second straight beam 30 may bend or compress about the pivot point 38. The first straight beam 28 and second straight beam 30 may extend from the parallel planes 25, 27 at angles between approximately 60-80 degrees and extend within the plane 29 of the X-shaped frame 26.

[0039] The first straight beam 28 and the second straight beam 30 may have upper ends 40, 42, respectively, opposite of lower ends 44, 46, respectively. The upper ends 40, 42 may correspond to attachment of the large annulus 12 while the lower ends 44, 46 may correspond to attachment of the small annulus 18 as further described below. The first straight beam 28 and the second straight beam 30 may

intersect such that the pivot point **38** is positioned closer to the lower ends **44, 46** as compared to the upper ends **40, 42** to provide a smaller distance between the lower ends **44, 46** corresponding to a smaller diameter of the small annulus **18** and a larger distance between the upper ends **40, 42** corresponding to a larger diameter of the large annulus **12**.

[0040] The first straight beam **28** and second straight beam **30** may compress toward each other about the pivot point **38** in a pivoting, scissors-like manner in which compression of the upper ends **40, 42** translates to compression of the lower ends **44, 46** and vice versa. This mechanism allows the patient to compress one of the upper ends **40, 42** and lower ends **44, 46** of the first straight beam **28** and second straight beam **30** thus resulting in the opposite ends to also compress.

[0041] The X-shaped frame **26** may be an injection molded elastomer **48** such as medical grade silicone, silicone rubber, rubber or the like. The elastomer **48** may have a stiffness between 30-70 durometer. The first straight beam **28** and second straight beam **30** may be the same length and may be between 4 cm and 9 cm in length, and at least 6 cm, and at least 7 cm, and at least 8 cm in length.

[0042] Extending within the elastomer **48** of each of the first straight beam **28** and second straight beam **30**, along a longitudinal axis of the beams proximate a center of the cross section of the beams, may be rigid internal support wires **50, 52**, respectively, increasing the rigidity of the first straight beam **28** and second straight beam **30** and further facilitating the scissors-like movement of the X-shaped frame **26**. The internal support wires **50, 52** may be stainless-steel wires, for example 20-gauge stainless steel wires. The internal support wires **50, 52** may be between 4 cm and 9 cm in length, and at least 6 cm, and at least 7 cm, and at least 8 cm in length and generally correspond to and extend along a length of the first straight beam **28** and second straight beam **30** respectively. The wires **50, 52** may be overlapping within the elastomer **48** and separated by about 0.02 mm or about 0.01-0.03 mm at the pivot point **38** due to intervening elastomer **48**.

[0043] A cross-section of each of the first straight beam **28** and second straight beam **30** may take the form of a circle or oval cross-section having a diameter of between 0.25 cm and 1.5 cm and less than 1.5 cm and less than 1 cm and less than 0.5 cm and about 0.5 cm to provide the necessary strength yet facilitate a desired compressibility of the frame material. The first straight beam **28** and second straight beam **30** may also have a cross-section of other known shapes such as square and rectangle.

[0044] It is understood that the elastomer **48** and internal support wires **50, 52** of the first straight beam **28** and second straight beam **30** allow the X-shaped frame **26** to compress inward when pinching forces **54** are applied to upper ends **40, 42** or lower ends **44, 46** of the X-shaped frame **26** while rebounding back to its original form when the force is released. The resilience and elasticity of the elastomer **48** allows for repeated flexing without losing its ability to rebound back to its original shape and size.

[0045] The X-shaped frame **26** may have a flexure reducing the distance between the upper ends **40, 42**, respectively, or lower ends **44, 46**, respectively, by at least 50% under a force less than 40 N, which has been identified as the average maximum pinch force that patients with limited dexterity can apply. In this respect the X-shaped frame **26** may be compressed with a low threshold manual force.

[0046] The upper ends **40, 42** of the X-shaped frame **26** may be attached to the large annulus **12** at diametrically opposed ends of the large annulus **12**. In this respect a distance between the upper ends **40, 42** may generally correlate to a diameter of the large annulus **12**.

[0047] The large annulus **12** may be a ring having an outer diameter between 3.5 cm and 4.5 cm and at least 3.5 cm and at least 3.8 cm and at least 4.0 cm and about 4.0 cm in a relaxed state to be sized to engage an inner wall of a proximal end of the vagina **14** proximate the cervix **16** in an anchoring manner as further described below.

[0048] A cross-section of the large annulus **12** may be a circle or oval cross-section having a diameter between 0.25 cm and 1.5 cm and less than 1.5 cm and less than 1 cm and less than 0.5 cm and about 0.5 cm to provide a desired compressibility. The cross-section of the large annulus **12** is generally formed of a smooth or curved outer perimeter increasing the comfort of the contact between the large annulus **12** and the inner wall of the vagina **14**. The smooth outer surface of the large annulus **12** also prevents scarring or tearing of the vagina **14**.

[0049] The large annulus **12** may be an injection molded elastomer such as medical grade silicone, silicone rubber, rubber or the like. The elastomer may have a stiffness between 30-70 durometer. The elastomer allows the material to flex inward when pinching forces **54** are applied to opposite ends of the large annulus **12** while rebounding back to its original form when the force **54** is released. The resilience of the elastomer allows for repeated flexing without losing its ability to rebound back to its original shape and size.

[0050] The large annulus **12** may have a flexure reducing the diameter of the large annulus **12** in at least one direction by at least 50% under a force less than 40 N, which has been identified as the average maximum pinch force that patients with limited dexterity can apply. In this respect the large annulus **12** may be compressed under a low threshold pinch force while still providing sufficient resistance or rebounding force to engage the inner wall of the vagina **14**.

[0051] The lower ends **44, 46** of the X-shaped frame **26** may be attached to the small annulus **18** at diametrically opposed ends of the small annulus **18**. In this respect a distance between the lower ends **44, 46** may generally correlate to a diameter of the small annulus **18**.

[0052] The small annulus **18** may be a ring having an outer diameter of between 1.5 cm and 2.5 cm and at least 1.5 cm and at least 2 cm and about 2 cm to be sized in a relaxed state to engage an inner wall of a distal end of the vagina **14** proximate the opening **22** of the vagina **14** in a supportive manner posterior to the mid-urethra **24** as seen in FIG. 3 and further described below.

[0053] A cross-section of the small annulus **18** may be a circle or oval having a diameter of between 0.25 cm and 1.5 cm and less than 1.5 cm and less than 1 cm and less than 0.5 cm and about 0.5 cm to facilitate a desired compressibility. The cross-section of the small annulus **18** is generally formed of a smooth or curved outer perimeter increasing the comfort of the contact between the small annulus **18** and the inner wall of the vagina **14**. The smooth outer surface of the small annulus **18** also prevents scarring or tearing of the vagina **14**.

[0054] The small annulus **18** may be an injection molded elastomer such as medical grade silicone, silicone rubber, rubber or the like. The elastomer may have a stiffness

between 30-70 durometer. The elastomer allows the material to flex inward when pinching forces **54** are applied to opposite ends of the small annulus **18** while rebounding back to its original form when the force is released. The resilience of the elastomer allows for repeated flexing without losing its ability to rebound back to its original shape and size.

**[0055]** The small annulus **18** may have a flexure reducing the diameter of the small annulus **18** in at least one direction by at least 50% under a force less than 40 N which has been identified as the average maximum pinch force that patients with limited dexterity can apply. In this respect the small annulus **18** may be compressed under a low threshold pinch force while still providing sufficient resistance or rebounding force to engage the inner wall of the vagina **14**.

**[0056]** Referring also to FIG. 2, the large annulus **12** and the small annulus **18** may be spaced apart by the X-shaped frame **26** to be positionable within the vagina **14** at desired anatomical positions. The pessary **10** may have a total length, measured along the axis of separation **31**, between 4 cm and 10 cm and at least 5 cm and at least 6 cm and at least 7 cm and at least 8 cm and about 8 cm. The length of the pessary **10** may approximate an average length of the vagina **14** between a position just below the cervix **16** and a position within the vagina posterior to the mid-urethra **24**. A shortened length may be used to accommodate a shortened vaginal length after hysterectomy in postmenopausal patients.

**[0057]** A greatest width of the pessary **10** may be defined by the diameter of the large annulus **12** which is sized to engage a greatest diameter of the vagina **14** to provide a supportive anchoring or “foothold” to the wall of the vagina **14** and to prevent longitudinal movement of the pessary **10**. It is understood that the large annulus **12** may engage a slightly widened proximal end of the vagina **14** as the vagina **14** approaches the cervix **16**.

**[0058]** The diameter of the small annulus **18** is generally smaller than the large annulus **12** and sized to support a narrower diameter of the vagina **14** proximate the opening **22** of the vagina **14**. For example, the diameter of the small annulus **18** may be 30% to 60% smaller than the large annulus **12**. Although the small annulus **18** is intended to provide some anchoring functions, the smaller diameter of the small annulus **18** desirably fits comfortably within the vagina **14** in a supporting manner behind the mid-urethra **24**.

**[0059]** It is understood that the sizing of the pessary **10**, for example, the length and width of the pessary **10**, and diameters of the large annulus **12** and small annulus **18** will depend on the size of the vagina **14** of the patient and may be fitted according to each patient’s dimensions.

**[0060]** Exemplary dimensions of the pessary **10** are shown below in Table 1, for example, having two different sizes, i.e., “short” and “long”, to accommodate varying anatomical sizes of the patient. It is contemplated that at least five different sizes of pessary **10** may be manufactured to accommodate different vagina **14** sizes.

TABLE 1

Feature	Short	Long
Large Ring Diameter	3.5 cm	4 cm
Small Ring Diameter	2 cm	2 cm
Device (silicone) Thickness	0.5 cm	0.5 cm

TABLE 1-continued

Feature	Short	Long
Length	5 cm	8 cm
Volume Silicone	5 mL	6 mL

**[0061]** It is understood that the X-shaped frame **26**, the large annulus **12**, and small annulus **18** may be injection molded in a single mold as an integral or unitary piece in order to eliminate any breaks or seams between respective parts which may cause dirt or debris to enter the pessary **10**, and eliminating the need to attach the X-shaped frame **26** to the large annulus **12** and small annulus **18** after injection molding the separate parts. The internal support wires **50**, **52** may be molded within the elastomer **48** with the assistance of cured silicone squares to center the ends of the support wires **50**, **52** within the mold. The elastomer **48** is then injected into the mold and then the mold is heat cured. Additional curing of the pessary **10** and sterilization is completed before use by patients.

**[0062]** Referring now to FIGS. 2 and 3, when the pessary **10** is in use by the patient, the patient may compress a distal end **56** of the pessary **10** proximate the small annulus **18** and desirably positionable at a distal end of the vagina **14**, whereby compression is translated to a proximal end **58** of the pessary **10** proximate the large annulus **12** and desirably positionable at a proximal end of the vagina **14**.

**[0063]** The patient may apply a compression force **54** on the small annulus **18** by pinching opposite ends of the small annulus **18**. The patient may also apply a compression force **54** to the lower end of the X-shaped frame **26** by pinching the lower ends **44**, **46** together in a similar manner. The compression of the distal end **56** may be done manually without tools and with a single hand without physician assistance. The compression force **54** is translated to the upper ends **40**, **42** and the large annulus **12** to compress the large annulus **12**. The simultaneous compression of the small annulus **18**, X-shaped frame **26**, and large annulus **12** therefore provides an outer dimension or greatest width of the pessary **10** that is reduced in at least one direction whereby the pessary **10** may be more easily inserted into the vagina **14** by the patient.

**[0064]** The patient may insert the pessary **10** through the opening **22** of the vagina **14** with the large annulus **12** entering the vagina **14** first, followed by the X-shaped frame **26**, and lastly followed by the small annulus **18**. The desired positioning of the pessary **10** places the small annulus **18** between 1 cm and 2 cm inward from the opening **22** of the vagina **14** or between 1 cm and 2 cm below a protrusion of the vagina **14** formed by the pubic bone. This location of the small annulus **18** positions the posterior support of the pessary **10** substantially behind and slightly below the mid-urethra **24**. By virtue of the placement of the small annulus **18** and the length of the X-shaped frame **26**, the large annulus **12** is positionable at the proximal end of the vagina **14** proximate the cervix **16**.

**[0065]** Once the pessary **10** is inserted to the desired depth within the vagina **14**, the patient may release the compression force **54** on the small annulus **18** and/or the X-shaped frame **26** so that the small annulus **18**, X-shaped frame **26** and large annulus **12** rebound back to their relaxed states within the vagina **14**.

**[0066]** In the relaxed state the large annulus **12** may provide an outward radial force against the inner walls of the

vagina 14 thus “anchoring” the large annulus 12 to the vagina 14. In this respect the large annulus 12 may prevent or reduce the longitudinal movement of the pessary 10 along the vagina 14 preventing the pessary 10 from dislodging from the vagina 14 occurring, for example, during patient movement. The radial distributed contact of the large annulus 12 about a perimeter of the inner walls of the vagina 14 distributes the pressure placed on the inner walls of the vagina 14 to minimize discomfort to the patient.

[0067] Referring to FIG. 3, the expansion of the small annulus 18 to the relaxed state further provides an outward radial force against the inner walls of the vagina 14 providing an opposing force 60 against intra-abdominal pressures 62 placed on the mid-urethra 24. In this position the small annulus 18 acts as a backstop to passively support the mid-urethra 24 underneath the urethra when intra-abdominal pressures 62 place downward forces on the mid-urethra 24 such as during physical activity.

[0068] When the patient desires to remove the pessary 10, the patient may reach into the vagina 14 and locate the small annulus 18 proximate the opening 22 of the vagina 14 and apply a compression force 54 on the small annulus 18 and/or the lower end of the X-shaped frame 26 to translate further compression of the large annulus 12 and to the pessary 10 out of the vagina 14.

[0069] It is contemplated that the pessary 10 may be made of a material that is biocompatible, easy to clean (sterile) for repeated use, and safe for medical applications. The pessary may be able to withstand an internal body temperature of about 98.6 degrees Fahrenheit. The pessary 10 may weigh less than 10 grams.

[0070] It is also contemplated that the pessary 10 may be durable enough to be used repeatedly daily (for at least 12 hours) and to be taken out at night, for a duration of at least ninety days. The pessary 10 may be reused for at least 5 years without significant wear and tear.

[0071] The pessary 10 may be able to stop at least 60% and at least 90% of urine leakage during an episode of incontinence.

[0072] “Anterior” refers to the front of the human body, and “posterior” refers to the back of the human body.

[0073] Certain terminology is used herein for purposes of reference only, and thus is not intended to be limiting. For example, terms such as “upper”, “lower”, “above”, and “below” refer to directions in the drawings to which reference is made. Terms such as “front”, “back”, “rear”, “bottom” and “side”, describe the orientation of portions of the component within a consistent but arbitrary frame of reference which is made clear by reference to the text and the associated drawings describing the component under discussion. Such terminology may include the words specifically mentioned above, derivatives thereof, and words of similar import. Similarly, the terms “first”, “second” and other such numerical terms referring to structures do not imply a sequence or order unless clearly indicated by the context.

[0074] When introducing elements or features of the present disclosure and the exemplary embodiments, the articles “a”, “an”, “the” and “said” are intended to mean that there are one or more of such elements or features. The terms “comprising”, “including” and “having” are intended to be inclusive and mean that there may be additional elements or features other than those specifically noted. It is further to be understood that the method steps, processes, and operations

described herein are not to be construed as necessarily requiring their performance in the particular order discussed or illustrated, unless specifically identified as an order of performance. It is also to be understood that additional or alternative steps may be employed.

[0075] It is specifically intended that the present invention not be limited to the embodiments and illustrations contained herein and the claims should be understood to include modified forms of those embodiments including portions of the embodiments and combinations of elements of different embodiments as come within the scope of the following claims. All of the publications described herein, including patents and non-patent publications, are hereby incorporated herein by reference in their entireties.

What we claim is:

1. A pessary device insertable into a vagina for treating stress urinary incontinence comprising:

- a first annulus elastically deformable to bend inward and provide an outward radial force configured to engage opposing walls of the vagina;
- a second annulus elastically deformable to bend inward and provide an outward radial force configured to engage opposing walls of the vagina; and
- an elastic bridge connected between the first annulus and the second annulus and compressible to reduce a dimension of at least one of the first and second connected annulus.

2. The pessary device of claim 1 wherein a diameter of the second annulus is less than the first annulus.

3. The pessary device of claim 2 wherein the diameter of the first annulus is between 3 cm and 6 cm and a diameter of the second annulus is between 1 cm and 3 cm.

4. The pessary device of claim 1 wherein the first and second annulus provide a flexure reducing a diameter of the first and second annulus in at least one direction such that the first annulus and second annulus may be sized to be inserted into the vagina.

5. The pessary device of claim 4 wherein the first and second annulus are rings of silicone rubber.

6. The pessary device of claim 5 wherein the first and second annulus have a cross sectional diameter between 0.25 cm and 1 cm.

7. The pessary device of claim 1 wherein the first and second annulus provides a flexure reducing a width of the pessary at least 50% under less than 40 Newton force.

8. The pessary device of claim 1 wherein the elastic bridge comprises first and second intersecting rods having upper and lower ends of the first and second rods attached to diametrically opposite ends of the first and second annulus, respectively, wherein the first and second intersecting rods are compressible toward each other to further reduce a dimension of at least one of the first and second connected annulus.

9. The pessary device of claim 8 wherein a length of the first and second intersecting rods is between 4 cm and 9 cm.

10. The pessary device of claim 8 wherein an intersection of the first and second rods is closer to the second annulus than the first annulus.

11. The pessary device of claim 8 wherein the first and second intersecting rods are rigid wires coated with silicone rubber.

12. The pessary device of claim 8 wherein the first and second intersecting rods are compressible at least 50% toward each other under less than 40 Newton force.



**13.** A method of treating stress urinary incontinence in a human patient, the method comprising the steps of:

providing a pessary having a first annulus dimensioned to extend across opposing walls of a vagina opposite a second annulus dimensioned to extend across opposing walls of a vagina, the first and second annulus joined by an elastic bridge connected between the first annulus and the second annulus and compressible to reduce a dimension of at least one of the first and second connected annulus;

compressing at least one of the first annulus, the second annulus and the elastic bridge to reduce a width of the pessary to allow insertion of the pessary into the vagina;

inserting the pessary such that the first annulus is proximate a cervix and the second annulus is proximate an opening of the vagina posterior to a mid-urethra; and releasing the at least one of the first annulus, the second annulus and the elastic bridge to allow the first and second annulus to contact the opposing walls of the vagina.

**14.** The method of claim **13** wherein the elastic bridge comprises a pair of intersecting rods intersecting at a pivot

point and compressible toward each other to further compress at least one of the first and second annulus.

**15.** The method of claim **14** wherein compression of the first and second intersecting rods toward each other further compresses the first and second annulus to reduce a diameter of the other of the first and second annulus.

**16.** The method of claim **14** wherein a length of the first and second intersecting rods is between 4 cm and 9 cm.

**17.** The method of claim **13** wherein the second annulus is positioned posterior to the mid urethra to provide an opposing force when pressure is applied to the mid-urethra.

**18.** The method of claim **13** wherein compressing the at least one of the first annulus, second annulus and the elastic bridge reduces a width of the pessary by at least 50% under less than 40 Newton force.

**19.** The method of claim **13** wherein a diameter of the second annulus is less than the first annulus.

**20.** The method of claim **19** wherein the diameter of the first annulus is between 3 cm and 6 cm and a diameter of the second annulus is between 1 cm and 3 cm.

\* \* \* \* \*