



US 20230286212A1

(19) **United States**

(12) **Patent Application Publication**

Chen et al.

(10) **Pub. No.: US 2023/0286212 A1**

(43) **Pub. Date: Sep. 14, 2023**

(54) **POWDER SPREADER**

(52) **U.S. Cl.**

(71) Applicant: **Wisconsin Alumni Research Foundation, Madison, WI (US)**

CPC **B29C 64/218** (2017.08); **B33Y 10/00** (2014.12); **B33Y 30/00** (2014.12); **B29C 64/153** (2017.08)

(72) Inventors: **Lianyi Chen, Madison, WI (US); Luis Izet Escano, Madison, WI (US)**

(57) **ABSTRACT**

(21) Appl. No.: **17/694,378**

Aspects of the disclosure are directed to powder spreading and an apparatus therefor. As may be implemented in accordance with one or more embodiments, an apparatus having a flexible core and a shell on a surface of the core is used to displace powder in a powder bed. The shell has a low coefficient of friction, for example on the order of 0.10, and may operate to conduct static electricity away from the powder. The shell may be engaged with the powder to displace the powder and form a uniform powder layer having a planer upper surface, as the core is advanced across the powder bed.

(22) Filed: **Mar. 14, 2022**

Publication Classification

(51) **Int. Cl.**

B29C 64/218	(2006.01)
B33Y 10/00	(2006.01)
B33Y 30/00	(2006.01)
B29C 64/153	(2006.01)

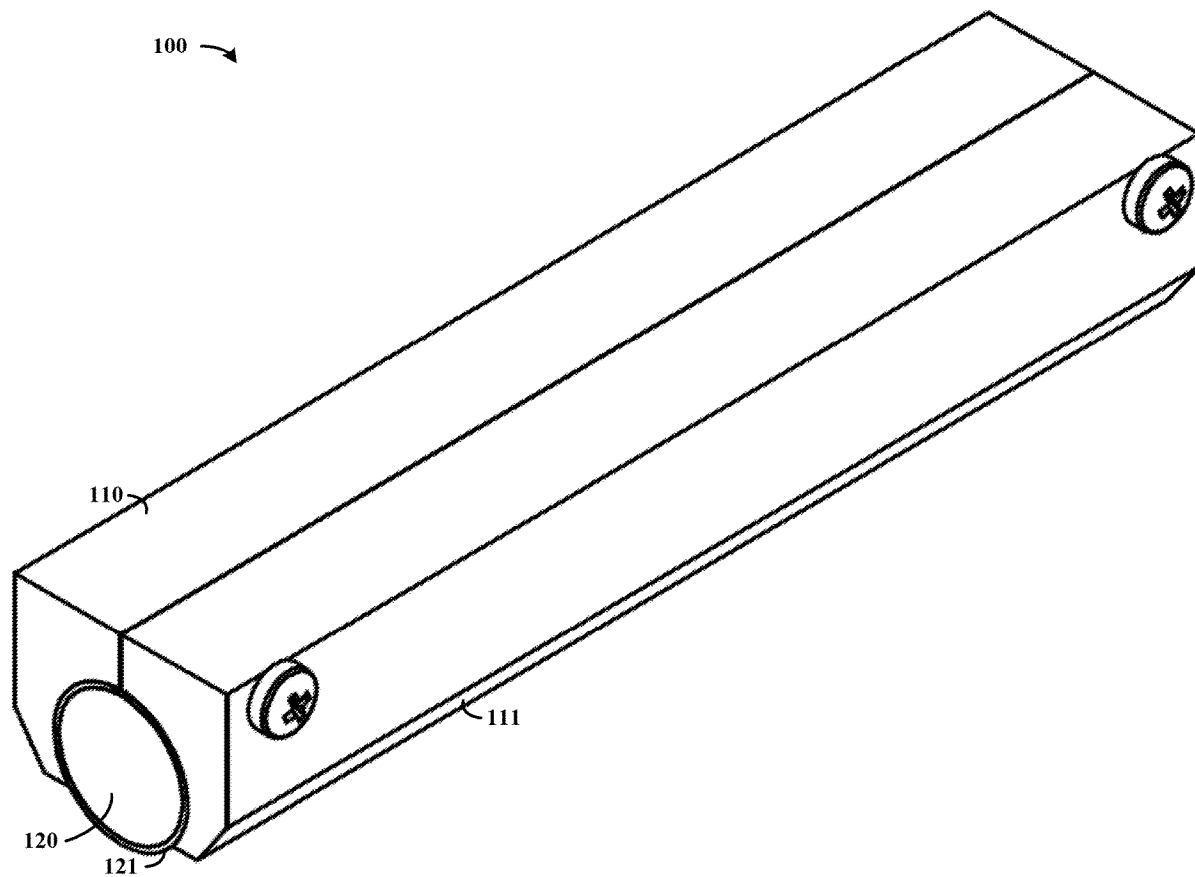

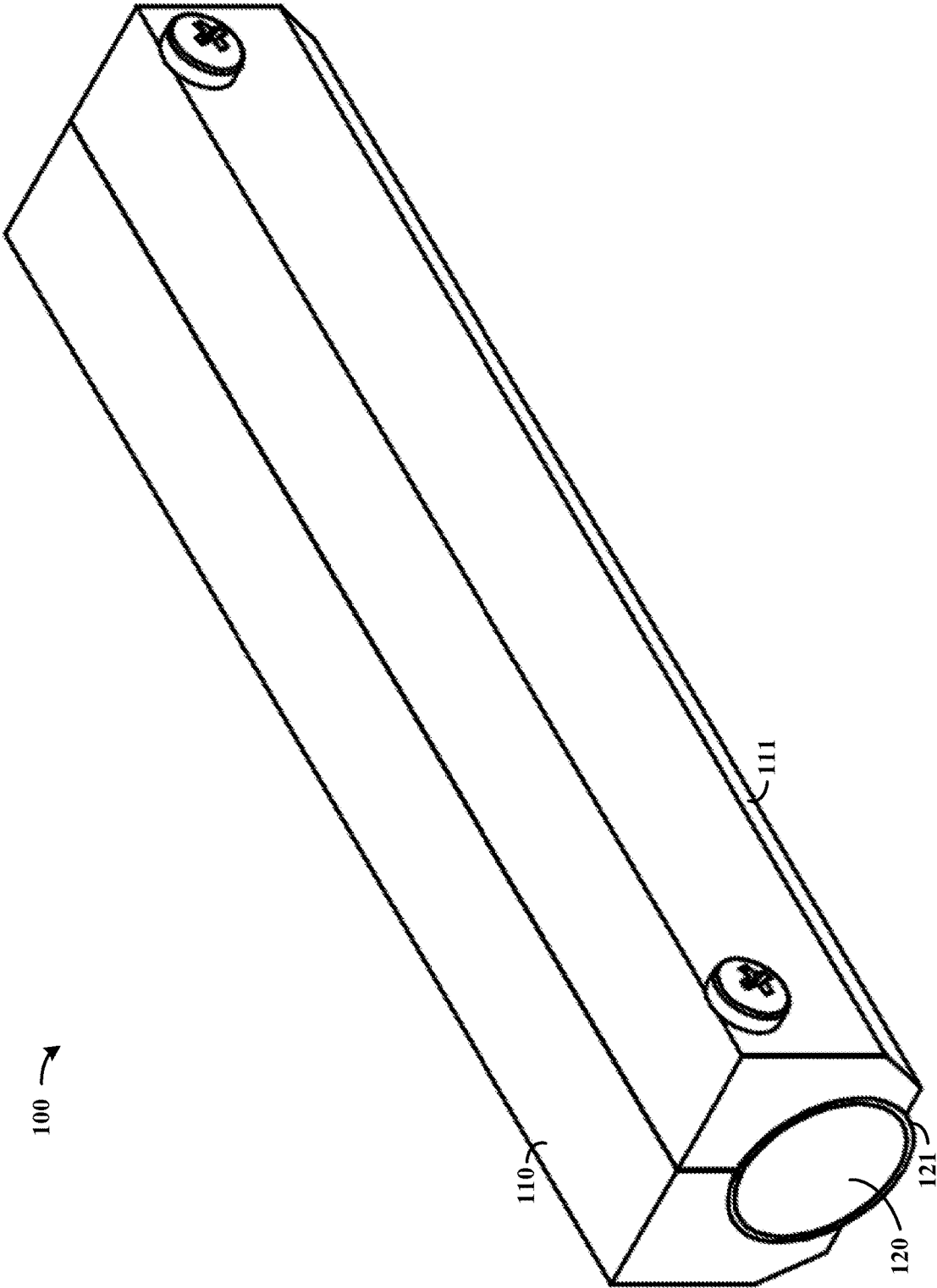

FIG. 1A

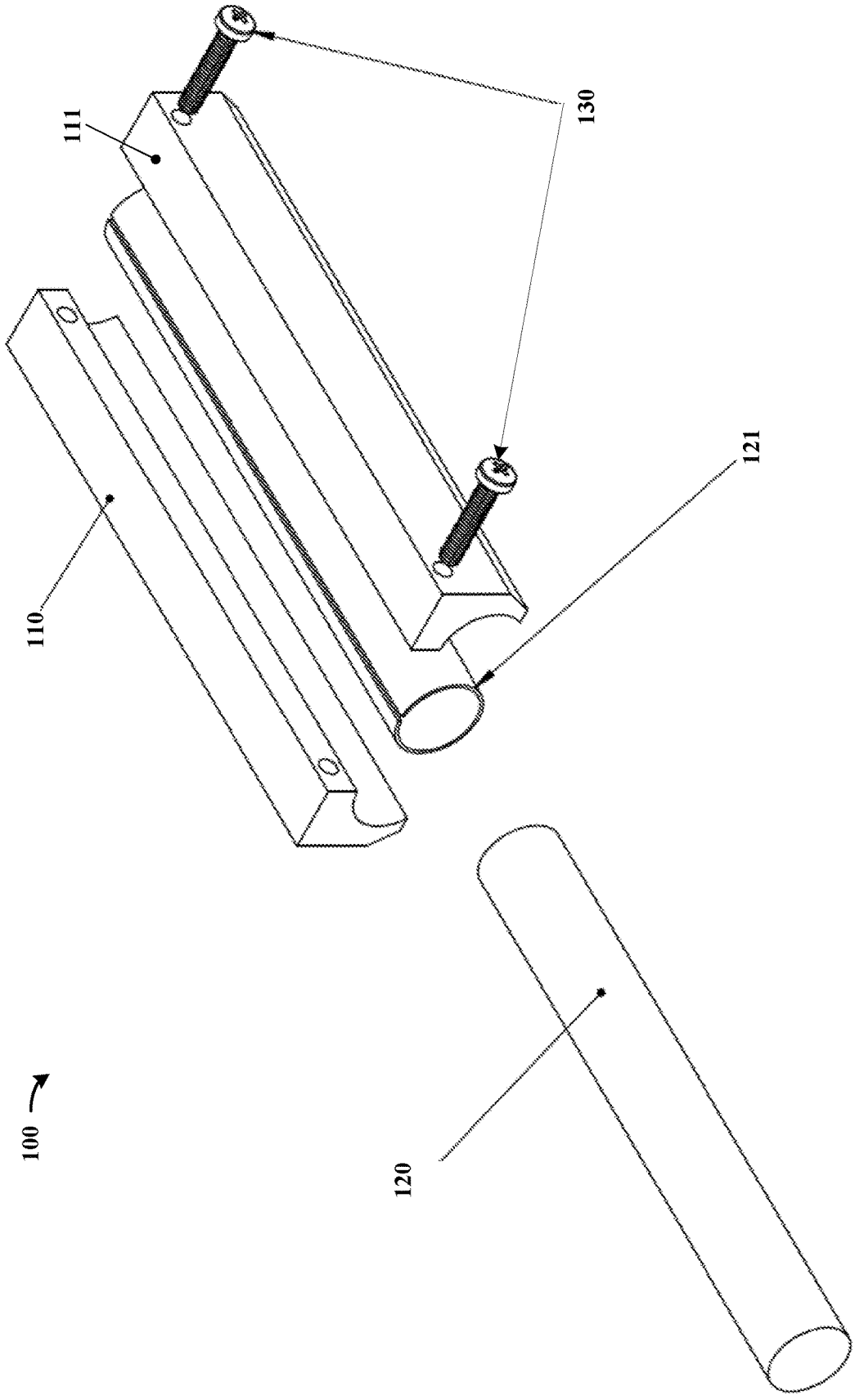

FIG. 1B

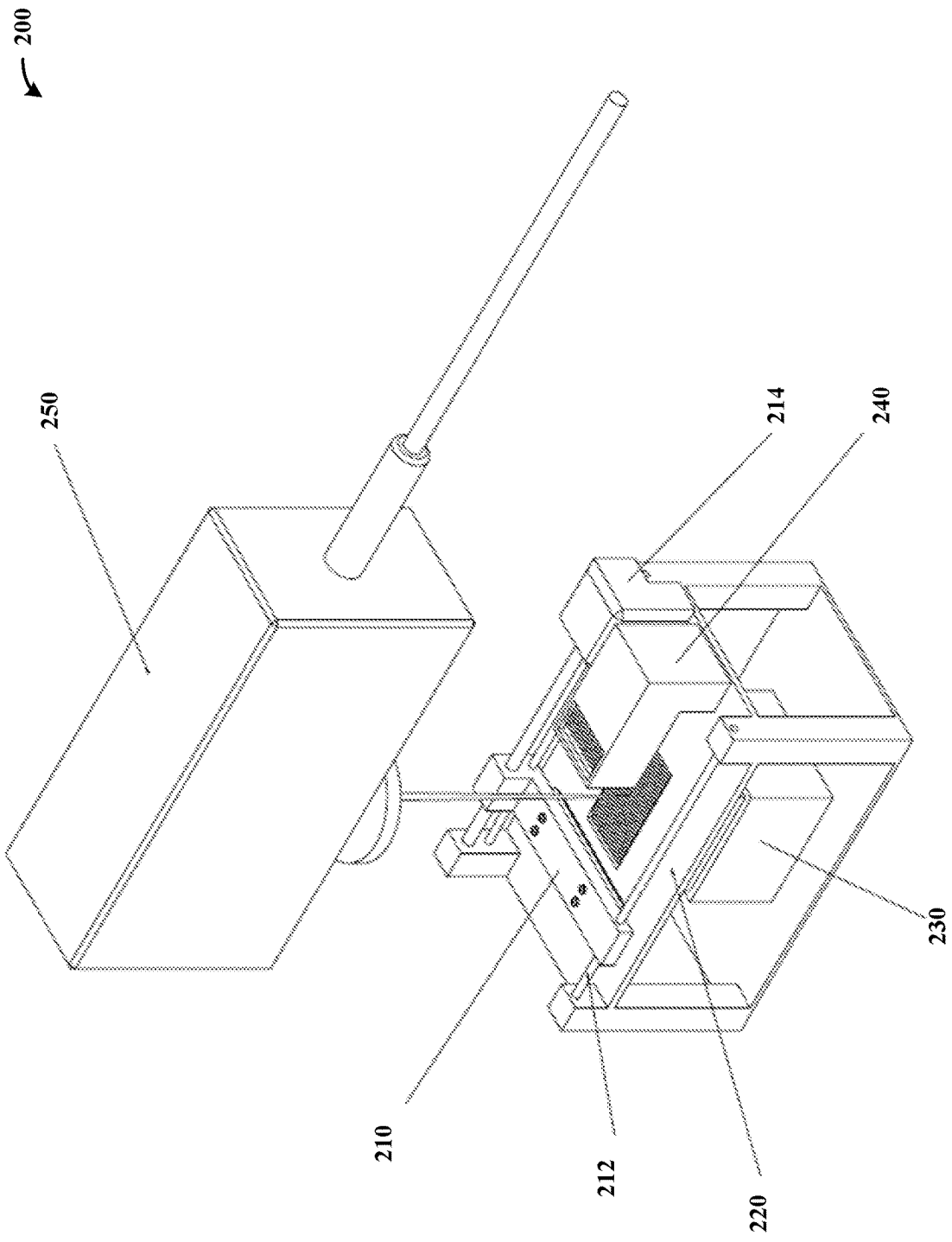

FIG. 2A

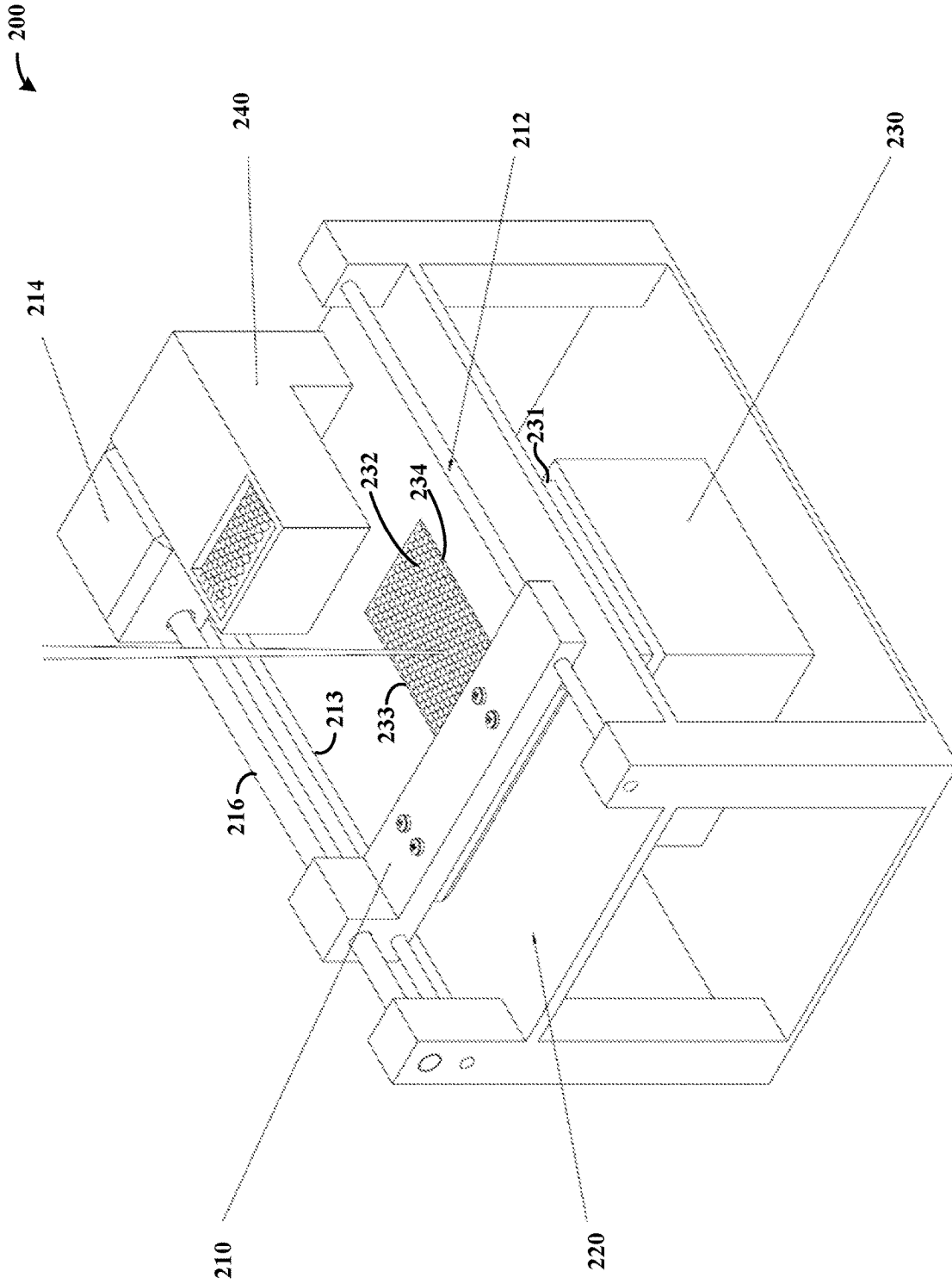

FIG. 2B

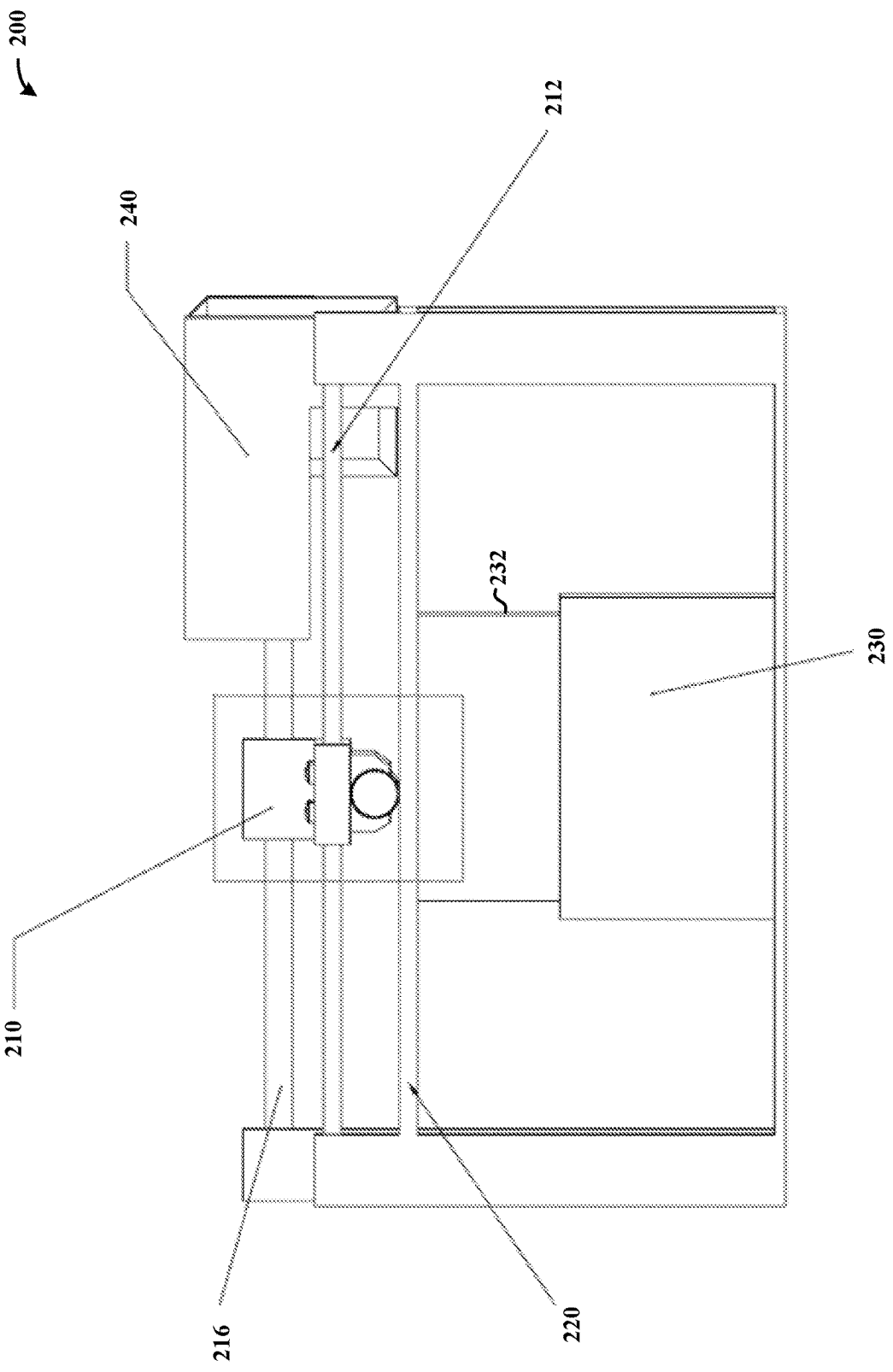

FIG. 2C

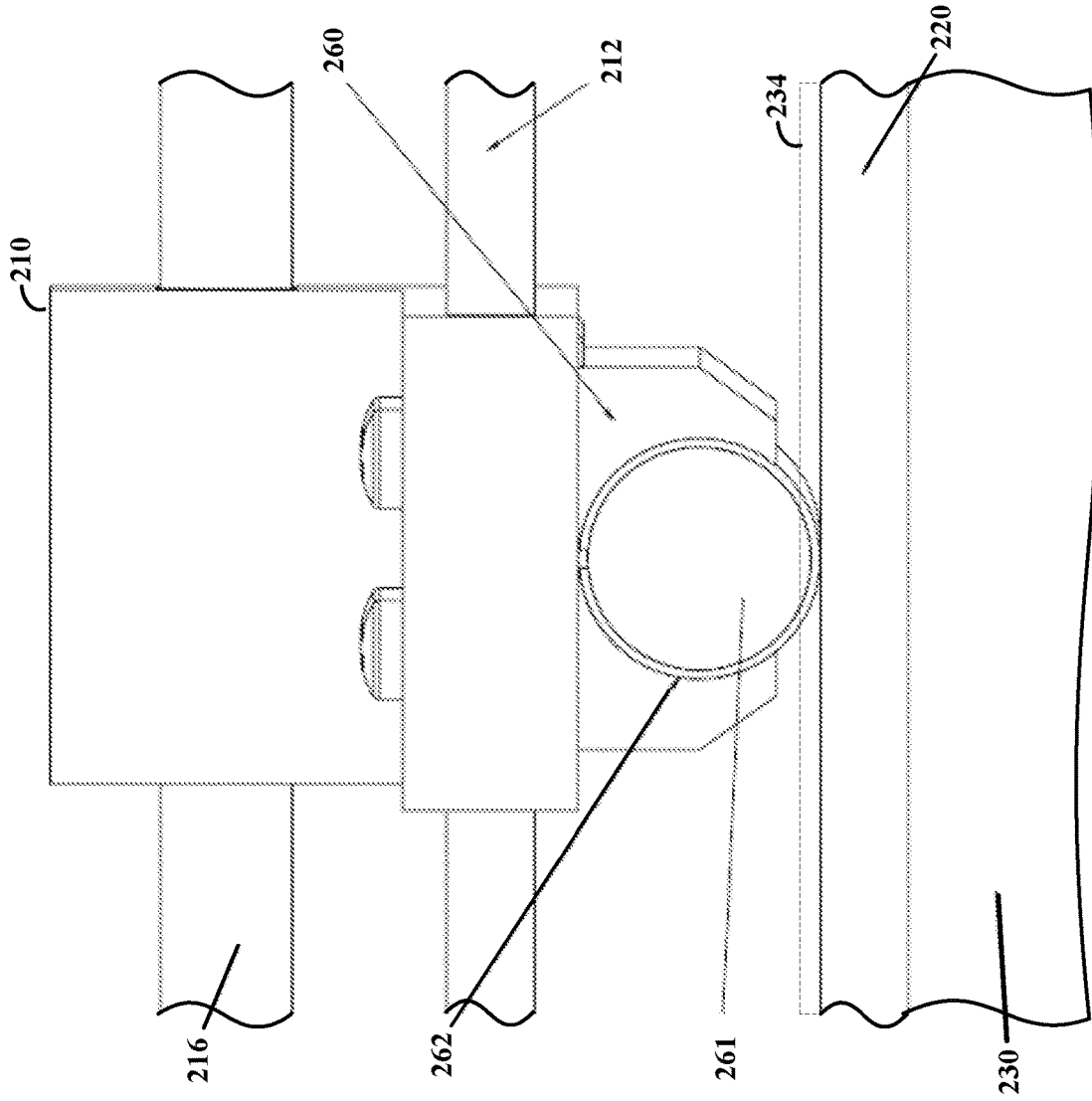

FIG. 2D

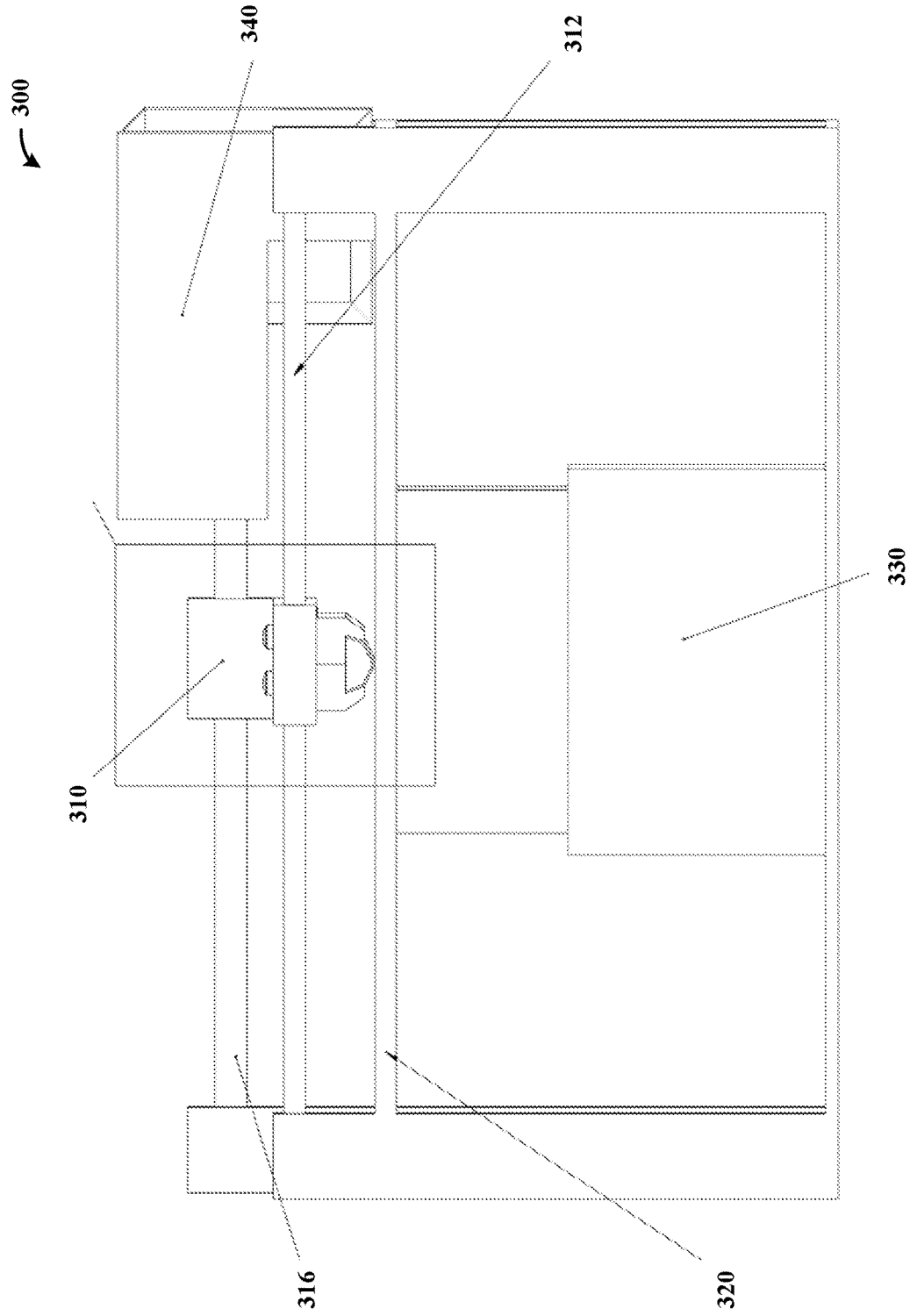

FIG. 3A

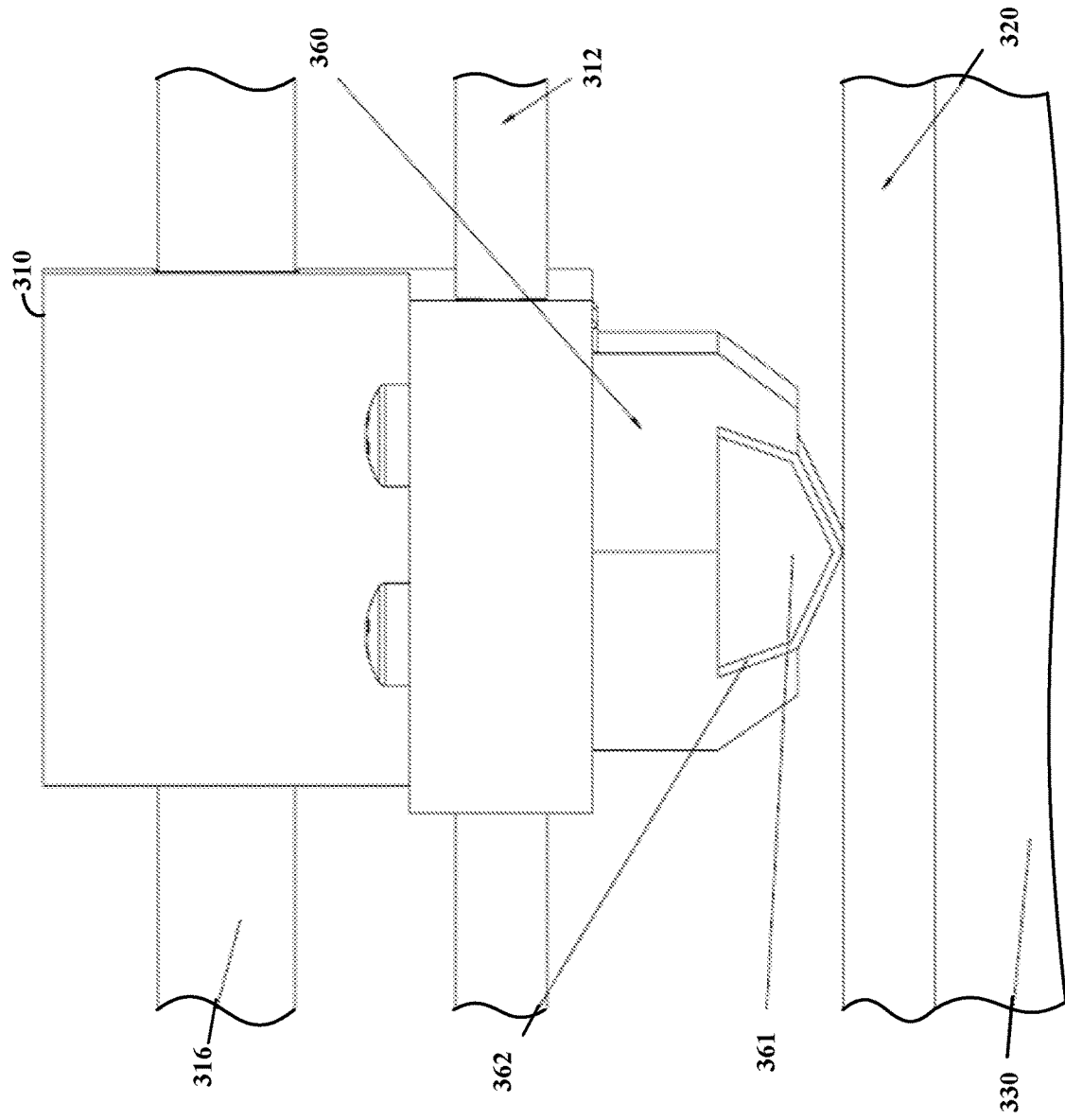

FIG. 3B

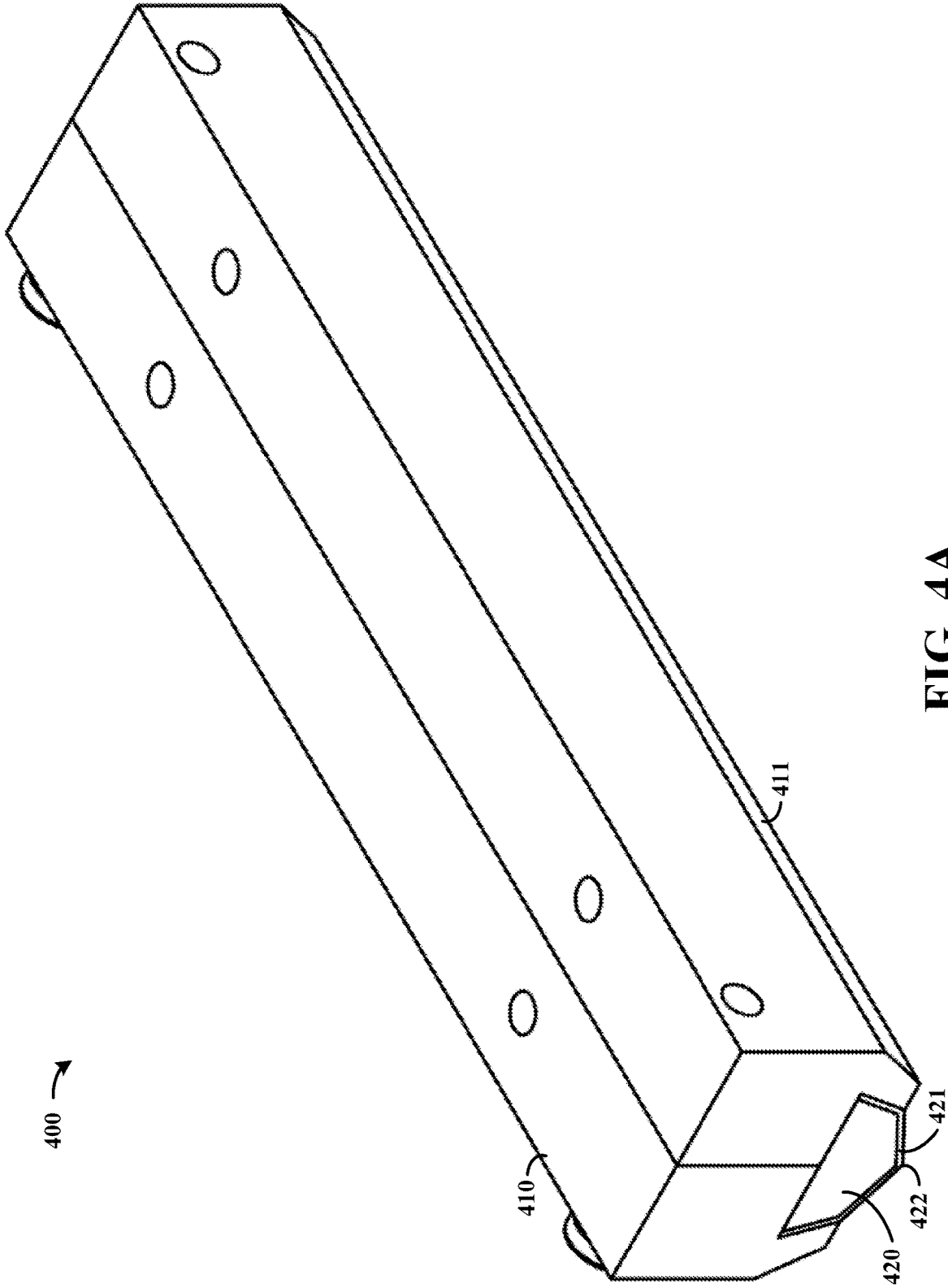
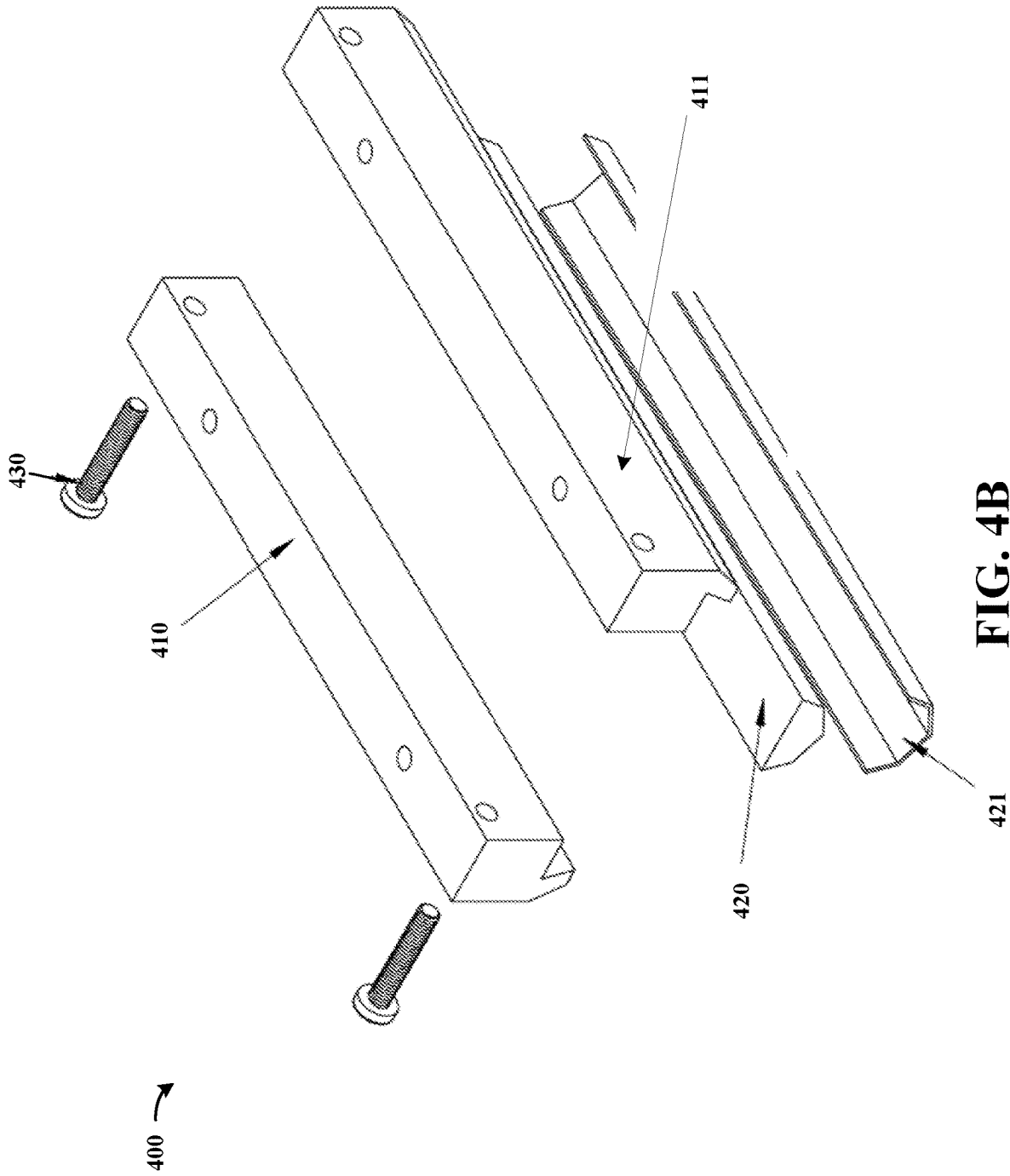

FIG. 4A



POWDER SPREADER

BACKGROUND

[0001] For many applications, it is desirable to control the distribution of powder for a variety of manufacturing processes. For instance, a spreader or re-coater, which may include a blade or rod, is used to spread powder over a substrate in powder bed-based additive manufacturing processes, such as laser powder bed fusion, electron beam powder bed fusion, and binder jetting. Such applications may utilize stainless steel, hard polymers, and/or a flexible heat resistant polymer, to maintain a reasonably homogeneous shape and resist heat during the spreading process.

[0002] While useful, such spreaders or re-coaters may exhibit issues relating to attaining desirable powder spreading. For instance, regions or zones of powder may be formed with uneven amounts of powder, irregular surfaces, and/or powderless zones. These issues may result in low part quality and undesirable variances, or may otherwise limit manufacturing speed.

[0003] These and other matters have presented challenges to powder spreaders and/or re-coaters, for a variety of applications.

SUMMARY

[0004] Various example embodiments are directed to powder spreaders, their application and their manufacture. Such embodiments may be useful for additive manufacturing processes, as may be implemented for providing a desirable powder surface at high manufacturing speeds.

[0005] As may be implemented in accordance with one or more embodiments, a powder spreader apparatus has a flexible core, a shell on a surface of the core, and a holder. The shell may have a coefficient of friction that is less than a coefficient of friction of the surface of the core. The holder is engaged with a first portion of a surface of the shell and being configured to hold the shell and flexible core in place with a second portion of the surface of the shell being exposed.

[0006] As may be implemented in accordance with certain embodiments, an apparatus for additive manufacturing includes a powder bed having sidewalls configured to contain powder for additive manufacturing, a spreader and an energy source. The spreader includes a flexible core, a shell on a surface of the core and a holder engaged with a first portion of a surface of the shell and being configured to hold the shell and flexible core in place with a second portion of the surface of the shell being exposed for engaging with the powder. The shell has a coefficient of friction that is less than a coefficient of friction of the surface of the core, the core and shell having a length extending perpendicularly between the sidewalls of the powder bed. The holder is configured with the shell, the core and the sidewalls to contain the powder within the powder bed and to provide a uniform layer of the powder having a planer upper surface by displacing the powder as the spreader advances across the powder bed. The energy source is configured to form a structure by heating portions of the uniform layer.

[0007] The above embodiments may be implemented in the context of one or more methods of making and/or using the apparatuses as disclosed. In a particular embodiment, a method is carried out as follows. A shell is engaged with powder in a powder bed, with the shell located on a surface

of a flexible core. The shell may have a coefficient of friction that is less than a coefficient of friction of the surface of the core. The powder is displaced to form a uniform layer of the powder having a planer upper surface, by engaging the shell with the powder and advancing the core across the powder bed.

[0008] The above discussion/summary is not intended to describe each embodiment or every implementation of the present disclosure. The figures and detailed description that follow also exemplify various embodiments.

BRIEF DESCRIPTION OF FIGURES

[0009] Various example embodiments may be more completely understood in consideration of the following detailed description and in connection with the accompanying drawings, in which:

[0010] FIG. 1A shows a powder spreader apparatus, in accordance with one or more embodiments;

[0011] FIG. 1B shows the powder spreader apparatus of FIG. 1A, in exploded form;

[0012] FIGS. 2A-2D show an apparatus for powder bed additive manufacturing as may be implemented in accordance with one or more embodiments, in which:

[0013] FIG. 2A shows a first isometric view of the apparatus and including a laser;

[0014] FIG. 2B shows a second isometric view of the apparatus including a laser;

[0015] FIG. 2C shows a side view of the apparatus; and

[0016] FIG. 2D shows an enlarged view including a powder spreader apparatus;

[0017] FIGS. 3A-3B show an apparatus for powder bed additive manufacturing as may be implemented in accordance with one or more embodiments, in which:

[0018] FIG. 3A shows a side view of the apparatus; and

[0019] FIG. 3B shows an enlarged view including a powder spreader apparatus; and

[0020] FIG. 4A shows a powder spreader apparatus, in accordance with one or more embodiments; and

[0021] FIG. 4B shows the powder spreader apparatus of FIG. 4A, in exploded form.

[0022] While various embodiments discussed herein are amenable to modifications and alternative forms, aspects thereof have been shown by way of example in the drawings and will be described in detail. It should be understood, however, that the intention is not to limit the invention to the particular embodiments described. On the contrary, the intention is to cover all modifications, equivalents, and alternatives falling within the scope of the disclosure including aspects defined in the claims. In addition, the term "example" as may be used throughout this application is by way of illustration, and not limitation.

DETAILED DESCRIPTION

[0023] Aspects of the present disclosure are believed to be applicable to a variety of different types of articles of manufacture, apparatuses, systems and methods involving powder spreaders or re-coaters. In certain implementations, aspects of the present disclosure have been shown to be beneficial when used in the context of powder-bed additive manufacturing processes, such as laser powder bed fusion, electron beam powder bed fusion, binder jetting) to spread powder over a substrate. While not necessarily so limited,

various aspects may be appreciated through a discussion of examples using such exemplary contexts.

[0024] According to various example embodiments, a powder spreader employs a powder interface component such as a roller or blade that exhibits a very low friction coefficient. For instance, a 99.5% graphite surface may exhibit a friction coefficient of less than 0.15, for example on the order of ~ 0.1 . Certain embodiments utilize other graphite surfaces, for instance such as a 95% graphite surface or a 100% graphite surface (e.g., with nominal impurities). In connection with these and other embodiments herein, it has been recognized/discovered that the use of a material having such a low friction coefficient in connection with powder bed spreaders results in reduced/minimal dragging forces on the powder. It has further been recognized/discovered that utilizing such a material that also exhibits high electrical conductivity can mitigate the accumulation of static electrical charges, which in turn mitigates instabilities in the powder and/or movement thereof. Utilization of such approaches may facilitate high-speed powder spreading while avoiding negative effects such as those characterized above with respect to the distribution/spreading of powder, quality of resulting products, and limitations in manufacturing speed.

[0025] In a particular application, a powder spreader includes a flexible core, such as a polymeric material (e.g., silicone rubber) core exhibiting a hardness of 80 D (using the Shore D durometer hardness scale), and a graphite foil, the latter of which may have a thickness of about 1 mm. This hardness is sufficient to keep the morphology of the spreader as it pushes powder into a substrate, and flexible enough to deform elastically during interaction with layer imperfections. The graphite foil is flexible as well, and may follow elastic deformation of the core. The graphite foil may be capable of withstanding a maximum of 870° C., while the silicone rubber is able to withstand temperatures within the range of -60° C. to 260° C. Accordingly, both materials are capable of withstanding the temperatures during the spreading process. Other materials may also be used to achieve similar properties, to suit particular applications.

[0026] Certain embodiments are directed to a powder spreader apparatus having a flexible core, a shell on a surface of the core, and a holder engaged with the core, for instance as may be implemented for engaging the shell with powder as characterized herein. For example, the holder may be engaged with a first portion of a surface of the shell, and configured to hold both the shell and flexible core in place with a second portion of the surface of the shell being exposed. The shell may have a coefficient of friction that is less than a coefficient of friction of the surface of the core, which may facilitate interaction with powder.

[0027] The shell may be implemented in a variety of manners. In some instances, the shell operates with the core and the holder to displace, upon interaction of the second portion of the surface of the shell with powder in a powder bed, the powder to form a uniform layer of the powder having a planer upper surface. This may be carried out as the core is advanced across the powder bed. The shell may be electrically conductive and configured to conduct static electrical charge away from powder engaged therewith. Further, the shell may be deposited on the surface of the core or otherwise attached thereto.

[0028] In some implementations, the core is a roller having a cylindrical shape defined by a cylindrical surface and

the shell has a cylindrical shape that covers the cylindrical surface. The holder has an inner cylindrical surface that is engaged with an outer cylindrical surface of the shell. The shell and core may be configured to rotate within the holder.

[0029] As may be implemented in accordance with one or more embodiments, an additive manufacturing apparatus includes a powder bed, a spreader and an energy source. The spreader may include a flexible core, a shell on a surface of the core and a holder engaged with the shell to hold the shell and flexible core in place with a portion of the surface of the shell being exposed for engaging with powder in the powder bed. The core and shell may have a length extending perpendicularly between the sidewalls of the powder bed. The holder may operate with the shell, the core and the sidewalls to contain the powder within the powder bed and to provide a uniform layer of the powder having a planer upper surface by displacing the powder as the spreader advances across the powder bed. A mechanical component may be coupled to the spreader and configured to move the spreader in a fixed direction in parallel with the sidewalls, for example to facilitate the aforementioned advancement. The energy source may form structures by heating portions of the uniform layer and, if applicable, heating portions of further uniform layers provided thereon.

[0030] The shell may be formed and implemented in a variety of manners. In some embodiments, the shell may have a coefficient of friction that is less than a coefficient of friction of the surface of the core (e.g., less than 0.15). The shell may be electrically conductive and configured to conduct static electrical charge away from powder engaged with the shell. The shell may be formed of one or more of a variety of materials, for instance with a surface that is 99.5% graphite with a friction coefficient of 0.1. The shell may be deposited on the surface of the core, or formed separately and attached to the core.

[0031] The core may also be formed and implemented in a variety of manners. The core may be a roller having a cylindrical shape defined by a cylindrical surface, in which instance shell also has a cylindrical shape that covers the cylindrical surface. The core may have a knife shape with blade end covered by the shell such that the shell interacts with the powder to provide a uniform layer as noted herein. The core may include a polymeric material or other material that deforms, for example by allowing the shell to deform while forming a uniform powder layer.

[0032] Various embodiments as noted herein may be implemented in the context of one or more methods of making and/or using the apparatuses as disclosed. In a particular embodiment, a uniform powder surface is formed as follows. A shell is engaged with powder in a powder bed, with the shell located on a surface of a flexible core. The shell may have a coefficient of friction that is less than a coefficient of friction of the surface of the core. The powder is displaced to form a uniform layer of the powder having a planer upper surface, by engaging the shell with the powder and advancing the core across the powder bed.

[0033] The powder may be displaced in a variety of manners. In some embodiments, a powder bed having sidewalls is utilized to contain the powder. The sidewalls are separated by a width that may correspond to a length of the shell and the flexible core that extends perpendicular to the sidewalls. For instance, the length of the shell and flexible core may be slightly less than the width by which the sidewalls are separated, to facilitate the forming of the

uniform layer with the shell and flexible core extending between the sidewalls. The shell and flexible core may be longer than the width of the sidewalls and used to extend over the sidewalls for forming the uniform layer at a level corresponding to a top edge of the sidewalls. In these and other embodiments, the core may be used to apply pressure to the powder via the shell while deforming a portion of the core applying the pressure. Further, the core and shell may be used to displace the powder in a lateral direction along a surface of the powder (e.g., perpendicular to movement of the core and shell).

[0034] The shell and the core may be held with a mechanical holder having an inner surface conformed to an outer surface of the shell. This inner surface may allow the shell to rotate within the holder with a portion of the outer surface of the shell exposed and engaged with the powder.

[0035] In some implementations, the method involves forming a structure from the powder by heating portions of the uniform layer and, thereafter, adding powder on an upper surface of the uniform layer. The steps of engaging the shell and displacing the powder are repeated with the added powder to form a further uniform layer. Portions of this further uniform layer may be heated to form additional portions of the structure.

[0036] Turning now to the figures, FIG. 1A and FIG. 1B respectively show assembled and exploded views of a powder spreader apparatus 100, as may be implemented in accordance with various embodiments. The powder spreader 100 includes opposing spreader holding components 110 and 111, spreader core 120 and shell 121. Bolts 130 operate to fasten the spreader holding components together for enclosing the shell 121 and accepting the spreader core 120 within.

[0037] The core 120 may include a flexible material such as a silicone rubber or other polymeric material. The shell 121 may include a foil having a low coefficient of friction, such as a graphite foil with a thickness set to facilitate deformation of the foil with the core 120. For instance, the shell may include a surface region having 99.5% graphite material, which may be about 1 mm in thickness. The holding components 110 and 111 may be made of a suitable material, such as stainless steel. In some implementations, the shell 121 is coated onto the core 120.

[0038] FIGS. 2A-2D show an apparatus 200 for powder bed additive manufacturing as may be implemented in accordance with one or more embodiments. Referring to FIGS. 2A and 2B, front and rear isometric views are respectively shown of the apparatus 200 with a laser system 250 that may form part of the apparatus 200. FIGS. 2C and 2D depict example side views. The apparatus 200 includes a powder spreader 210, spreader guide rails 212 and 213, and a spreader motion mechanism 214/216. The powder spreader 210 includes opposing spreader holding components 260, a spreader core 261 and shell 262, as may be implemented in a manner similar to core and shell 120/121 of FIG. 1A.

[0039] The apparatus 200 may also include a building platform 220 and a substrate vertical motion stage 230 operable for raising and lowering a substrate 231 upon which powder 232 is delivered via powder delivery system 240.

[0040] The powder spreader 210, guide rails 212 and 213, and motion mechanism 214/216 (e.g., with 216 being a threaded or other drive) may operate together to facilitate the

formation of a uniform powder surface on the substrate 231. In certain implementations, the powder spreader 210 may be implemented using the powder spreader apparatus depicted in FIGS. 1A and 1B.

[0041] In operation, the laser system 250 may be utilized to form a structure in powder 232 as follows. The powder delivery system 240 may deliver powder 232 onto the substrate 231, and the powder spreader 210 may be utilized to spread the powder 232 to form a uniform surface thereon. Laser 250 may be used to heat the powder and form structures therein. Additional such iterations may be provided, for instance by lowering the substrate 231 via the vertical motion stage 230, addition of further powder supplied by the powder delivery system 240, utilization of the powder spreader 210 to form another uniform surface with the additional powder followed by the formation of additional structures therefrom using the laser system 250.

[0042] The powder spreader 210 may be aligned perpendicularly to the powder bed substrate 232, within sidewalls that contain powder relative to the spreader. Referring to FIG. 2B, sidewalls 233 and 234 may facilitate containment of the powder 232. For instance, sidewalls may be within the building platform 220, and may include a portion extending above such a platform as depicted by way of example in FIG. 2D (with sidewall 234 extending above the surface of the building platform). The sidewalls may be made of high-purity glassy carbon. The substrate may be made of a suitable material, such as aluminum Al6061. The spreader may be adapted to spread powder over a workpiece as layers in the workpiece are formed.

[0043] FIGS. 3A-3B show an apparatus 300 for powder bed additive manufacturing, with a knife-type spreader, as may be implemented in accordance with one or more embodiments, with FIG. 3A depicting a side view of the apparatus FIG. 3B showing an enlarged view including a powder spreader apparatus. FIGS. 3A and 3B may be implemented, for example, in a manner similar to that depicted in FIGS. 2C and 2D, and in connection with a laser apparatus as depicted in FIG. 2A.

[0044] The apparatus 300 includes a powder spreader 310, a spreader guide rail 312 and a spreader motion mechanism component 316, for example as may be coupled to a motion mechanism such as motion mechanism 214 depicted in FIG. 2A. The powder spreader 310 includes opposing spreader holding components 360, a spreader core 361 and shell 362, as may be implemented in a manner similar to core and shell 420/421 of FIG. 4A. The apparatus 300 may also include a building platform 320 and a substrate vertical motion stage 330 operable for raising and lowering a substrate (e.g., as in 231) upon which powder is delivered via powder delivery system 340. The powder spreader 310, guide rail 312 and motion mechanism may operate together to facilitate the formation of a uniform powder surface on the substrate.

[0045] Referring to FIGS. 4A and 4B, a powder spreader apparatus 400 is respectively shown assembled and in exploded form. The apparatus 400 may be implemented, for example, as the powder spreader 310 in FIGS. 3A-3B. The powder spreader apparatus 400 includes opposing spreader holding components 410 and 411, as well as a spreader core 420 and shell 421 that include a knife-type shape coming to a point 422 at an underside thereof. Bolts 430 operate to fasten the spreader holding components together for enclosing the shell 421 and accepting the spreader core 420 within.

[0046] The core 420 may include a flexible material such as a silicone rubber or other polymeric material. The shell 421 may include a foil having a low coefficient of friction, such as a graphite foil with a thickness set to facilitate deformation of the foil with the core 420. As similar to the example discussed with FIGS. 1A and 1B, the shell 421 may include a surface region having 99.5% graphite material, which may be about 1 mm in thickness. The holding components 410 and 411 may be made of a suitable material, such as stainless steel. In some implementations, the shell 421 is coated onto the core 420.

[0047] Based upon the above discussion and illustrations, those skilled in the art will readily recognize that various modifications and changes may be made to the various embodiments without strictly following the exemplary embodiments and applications illustrated and described herein. For example, various shapes may be implemented for the roller cores shown and described herein, and alternative shapes such as knife-edge type shapes may be utilized. Such modifications do not depart from the true spirit and scope of various aspects of the invention, including aspects set forth in the claims.

What is claimed is:

1. An apparatus for additive manufacturing, the apparatus comprising:

a powder bed having sidewalls and being configured to contain powder for additive manufacturing;

a spreader including:

a flexible core;

a shell on a surface of the core, the shell having a coefficient of friction that is less than a coefficient of friction of the surface of the core, the core and shell having a length extending perpendicularly between the sidewalls of the powder bed; and

a holder engaged with a first portion of a surface of the shell and being configured to hold the shell and core in place with a second portion of the surface of the shell being exposed for engaging with the powder, the holder being configured with the shell, the core and the sidewalls to:

contain the powder within the powder bed; and

provide a uniform layer of the powder having a planer upper surface by displacing the powder as the spreader advances across the powder bed; and

an energy source configured to form a structure by heating portions of the uniform layer.

2. The apparatus of claim 1, wherein the shell has a coefficient of friction that is less than 0.15.

3. The apparatus of claim 1, wherein the shell is electrically conductive and configured to conduct static electrical charge away from powder engaged therewith.

4. The apparatus of claim 1, wherein the shell has a surface that is 99.5% graphite with a friction coefficient of 0.1.

5. The apparatus of claim 1, wherein the core is a roller having a cylindrical shape defined by a cylindrical surface, and the shell has a cylindrical shape that covers the cylindrical surface.

6. The apparatus of claim 1, wherein the core has a knife shape with a blade end covered by the shell and configured to interact the shell with the powder to provide the uniform layer.

7. The apparatus of claim 1, wherein the shell is layer deposited on a surface of the core.

8. The apparatus of claim 1, further including a mechanical component coupled to the spreader and configured to move the spreader in a fixed direction in parallel with the sidewalls.

9. The apparatus of claim 1, wherein the core includes a polymeric material.

10. A powder spreader apparatus including:

a flexible core;

a shell on a surface of the core, the shell having a coefficient of friction that is less than a coefficient of friction of the surface of the core; and

a holder engaged with a first portion of a surface of the shell and being configured to hold the shell and core in place with a second portion of the surface of the shell being exposed.

11. The apparatus of claim 10, wherein the shell is configured and arranged with the core and the holder to, upon interaction of the second portion of the surface of the shell with powder in a powder bed, displace the powder to form a uniform layer of the powder having a planer upper surface, as the core is advanced across the powder bed.

12. The apparatus of claim 10, wherein the shell is electrically conductive and configured to conduct static electrical charge away from powder engaged therewith.

13. The apparatus of claim 10, wherein:

the core is a roller having a cylindrical shape defined by a cylindrical surface;

the shell has a cylindrical shape that covers the cylindrical surface; and

the holder has an inner cylindrical surface that is engaged with an outer cylindrical surface of the shell, the shell and core being configured to rotate within the holder.

14. The apparatus of claim 10, wherein the shell is layer deposited on a surface of the core.

15. A method comprising:

engaging a shell with powder in a powder bed, the shell being located on a surface of a flexible core, and having a coefficient of friction that is less than a coefficient of friction of the surface of the core; and

displacing the powder to form a uniform layer of the powder having a planer upper surface, by engaging the shell with the powder and advancing the core across the powder bed.

16. The method of claim 15, wherein displacing the powder includes using a powder bed having sidewalls and that contains the powder, the sidewalls being separated by a width corresponding to a length of the shell and the core that extends perpendicular to the sidewalls, to facilitate the forming of the uniform layer.

17. The method of claim 15, wherein displacing the powder to form the uniform layer includes using the core to apply pressure to the powder via the shell while deforming a portion of the core applying the pressure.

18. The method of claim 15, further including holding the shell and the core with a holder having an inner surface conformed to an outer surface of the shell and that allows the shell to rotate within the holder with a portion of the outer surface of the shell exposed and engaged with the powder.

19. The method of claim 15, wherein displacing the powder includes moving the core and shell in a lateral direction along a surface of the powder.

20. The method of claim 15, further including forming a structure from the powder by:

- heating portions of the uniform layer;
- after heating the portions of the uniform layer, adding powder on an upper surface of the uniform layer;
- repeating the steps of engaging the shell and displacing the powder with the added powder to form a further uniform layer; and
- heating portions of the further uniform layer.

* * * * *